



NSK LINEAR GUIDES FOR INDUSTRIAL AUTOMATION AND EQUIPMENT



- **Five Types available in Commercial Grade**
- **LE Series Miniature - Wide Type**
- **LH Series for High Load Capacity Applications**
- **LS Series for Compact Low Profile Space Saving Conditions**
- **LU Series Miniature Type**
- **LW Series Wide Type**
- **Interchangeable Rails and Ball Slides**
- **Preload and Clearance Types available**
- **Fluoride Black Chrome Plated Rails and Ball Slides**
- **Large Inventory for Prompt Delivery**

CONTENTS

	PAGE
How to Use This Guide	3
Features	3
Identification Numbers – ‘LH’ Series	4
Accuracy Standard – ‘LH’ Series Load Rating and Life Calculation	5
Dimensional Tables – ‘LH’ Series Ball Slides	6, 7, 8, 9, 10, 11
Dimensional Tables – ‘LH’ Series Rails	12
Accessories – ‘LH’ Series	13
Identification Numbers – ‘LS’ Series	14
Accuracy Standard – ‘LS’ Series Load Rating and Life Calculation	15
Dimensional Tables – ‘LS’ Series Ball Slides	16, 17, 18, 19
Dimensional Tables – ‘LS’ Series Rails	20
Accessories – ‘LS’ Series	21
Identification Numbers – ‘LU’ Series	22
Identification Numbers – ‘LE’ Series	23
Identification Numbers – ‘LW’ Series	24
Assembly and Mounting Method	25
Lubrication & Grease Fittings	26
Grease Units	27, 28, 29, 30
Application Sheet – Rail Butting	31
K1 Maintenance-Free Lubrication System	32
Identification Numbers – ‘K1’ Maintenance-Free Lubrication System	33
K1 Handling and Assembly Instructions	34
Unit Conversion Chart	35

CAD DRAWING DATA

For LE/LH/LS/LU & LW-Series go to the toolkit page of the NSK website www.ca.nsk.com.

For 3D IGES files on CD-ROM of LH/LS-Series Linear Guides email marketing@ca.nsk.com.

Note: CAD DXF drawing files are also available for other linear motion products. Contact NSK.

HOW TO USE THIS GUIDE

Use this guide to select the linear guide ball slides, rails and accessories that you need for your application. Pages 4, 14, 22, 23, 24 and 33 provide identification numbers that you will need to order the components for your application.

If you have any uncertainties, or would like more detailed information about any aspect of linear guides, please contact your NSK representative at one of our locations listed on the back cover.

FEATURES

Interchangeability of Rail and Ball Slide

One important feature of the Gothic arch is its ability to make high accuracy measurements on both the ball slide and rail, allowing for their interchangeability. This means that additions and/or replacement of ball slides is easily done.

High Load Capacity and Long Life

NSK has developed an infinite ball recirculating type linear guide with the largest load capacity available (comparing equal size ball slides). This high load capability helps to ensure long life.

Compact Low profile Type

To minimize space, NSK has developed low profile linear guides to handle various applications.

Miniature and Miniature Wide Type Stainless Steel

If light loads and corrosive conditions are present for your application needs, NSK can supply a miniature and miniature wide type linear guide in stainless steel. NSK's built-in ball retainer system allows for easy installation and removal of ball slides.

Wide Type

If your application requires low profile combined with high load, NSK offers the wide series linear guides.

Shock Resistant Design

Another design feature of the Gothic arch is its ability to absorb vertical shock loads from above using four-row groove configuration. This design is favourable in case of unexpected accidents during installation, or the operation of equipment. The ball groove is designed to avoid edge loading under extreme loads, extending the life of the unit.

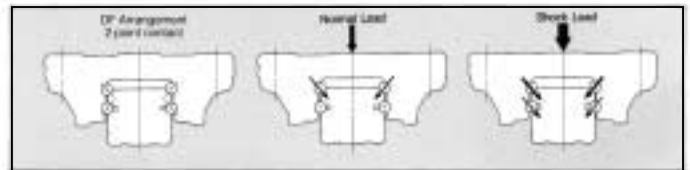

Normal load is carried on the top two grooves.
Shock load is carried by all four grooves.

Universal Slider

NSK has incorporated both thru and tapped holes into one flanged slider for a combination of mounting applications.

Ability to Butt Rails

Tolerance of ball grooves on the ball slides and rails are controlled to allow for butting, giving you the flexibility of unlimited lengths. We can offer a stocked linear guide rail with versatility in assembling preloaded or clearance type ball slides.

K1 Maintenance Free Lubrication System

NSK has the K1 for all five series of interchangeable linear guides. These lubricating units are all available from stock.

Maximum Rail Length in one section available up to 4,000 mm.

Short Delivery Time

We can ship from our large inventory, both standard and custom cut-to-length linear rails.

Fluoride Black Chrome Plating

NSK has a black chromium plating for linear bearings and rails to cover conditions requiring wet, corrosive and clean room applications. These are available from stock.

LH Series

Identification Number Ball Slide

Refer to following numbering system when ordering.
Refer to Page 12 for Rail Identification Number.

NOTE:

Single seal installed each side as standard. All slides come with a grease fitting. A brass extension connector is installed with K1 Lubrication Units to accept the grease fitting.

Ball Slide (Stocked item)

LAH 25 AN Z - K2P

Ball Slide Type

Size No.

- AN: Square - Standard
- BN: Square - Long
- FL: Flanged (Thru hole) Standard
- HL: Flanged (Thru hole) Long
- EM: Flanged (Tapped & Thru hole) Standard
- GM: Flanged (Tapped & Thru hole) Long
- EL: Flanged (Tapped hole) Standard
- GL: Flanged (Tapped hole) Long

No code: No special accessories and fluoride black chrome plating

- K: One K1 Lubrication Unit each side
- K2: Two K1 Lubrication Units each side
- D: Double Seals each side
- P: Protector Plate each side

- DP: Double Seals + Protector Plate each side
- KD: One K1 Unit + Double Seals each side
- K2D: Two K1 Units + Double Seals each side
- KP: One K1 Unit + Protector Plate each side
- K2P: Two K1 Units + Protector Plate each side

- F: Fluoride Black Chrome Plating
- FK: Fluoride Black Chrome Plating + One K1 Unit
- FK2: Fluoride Black Chrome Plating + Two K1 Units
- FKD: Fluoride Black Chrome Plating + One K1 Unit + Double Seals each side
- FKDP: Fluoride Black Chrome Plating + One K1 Unit + Double Seals each side + Protector Plate each side
- FD: Fluoride Black Chrome Plating + Double Seals each side

- No code: Clearance type
- Z: Preloaded type

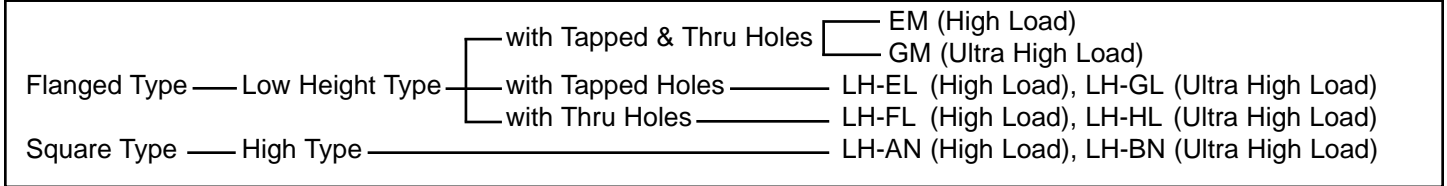

Fig.-1 LH-AN, LH-BN TYPE

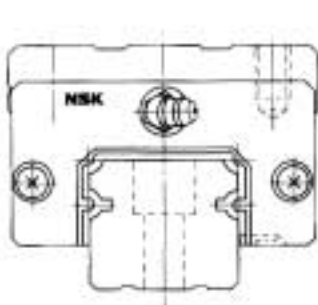

Fig.-2 LH-EL, LH-GL TYPE
LH-FL, LH-HL TYPE

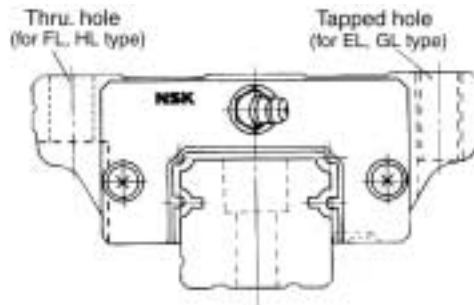
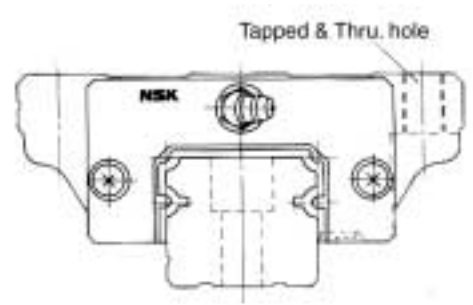

Fig.-3 LH-EM, LH-GM TYPE



Internal Clearance and Preload

The internal clearance refers to the amount of movement of the ball slide, when moved up and down with the rail fixed. The amount of preload is specified by size as follows.

Table 1

Unit: μm

Size	#15	#20	#25	#30	#35	#45	#55	#65
Clearance	15~-4				15~-5			
Preloaded	0~-4	0~-5		0~-7		0~-9		

Accuracy Standard

The accuracy standard of the NSK “High Load Capacity LH-Series” is shown in Table 1. With high-accuracy control of individual rail size and interchangeability, the accuracy of Table 1 can be maintained sufficiently even after addition or replacement of the ball slide.

Table 1 Tolerances		Unit : μm	
Tolerances (See Fig. 4 for Symbols)		Model No. LH	
		15, 20, 25, 30, 35	45,55,65
Clearance Type	Overall Height, H	± 20	± 30
	Lateral Width, W_2	± 30	± 35
Preload Type	Overall Height, H	± 20	± 30
	Lateral Width, W_2	± 30	± 35
Running Parallelism of Face $\square C$ to Face $\square A$		Refer to Fig. 4	
Running Parallelism of Face $\square D$ to Face $\square B$			

W_2 is applicable to the reference side only. Note: during installation the reference side is indicated by a line provided on the side of ball slide and rail. (See Fig. 4)

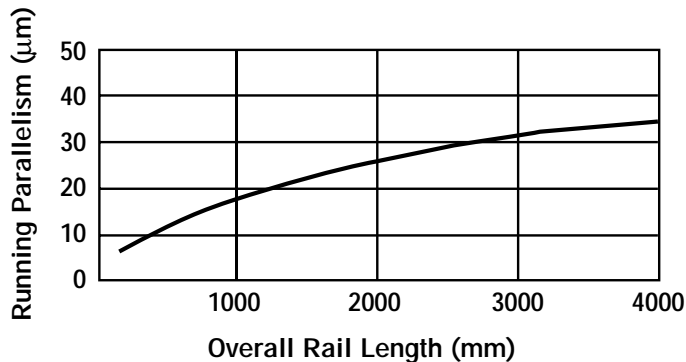

Fig. 3 Running Parallelism

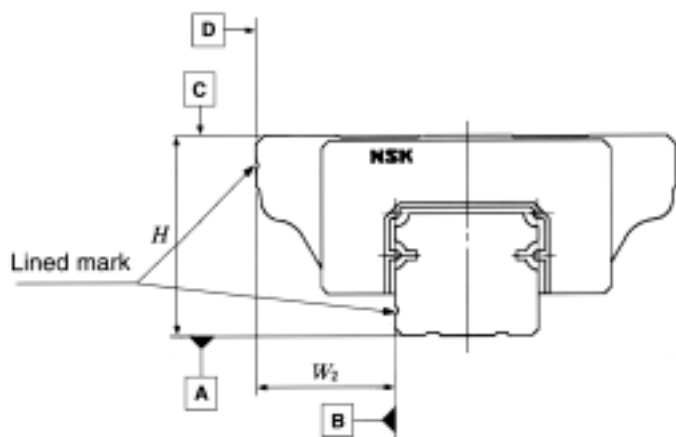

Fig. 4 Accuracy Standard

Load Rating and Life

The LH-Series is based on a design applying load from above. Therefore the dimension table shows the basic dynamic load rating C and basic static load rating C_0 for the downward direction. If the load is applied laterally or upward refer to values in Table 2.

Table 2 Basic Load Rating Correction for Direction

Load Direction	Basic Dynamic Load Rating	Basic Static Load Rating
Downward	C	C_0
Upward	C	$0.75C_0$
Laterally	$0.88C$	$0.63C_0$

Estimate the life of linear guides using the equation below.

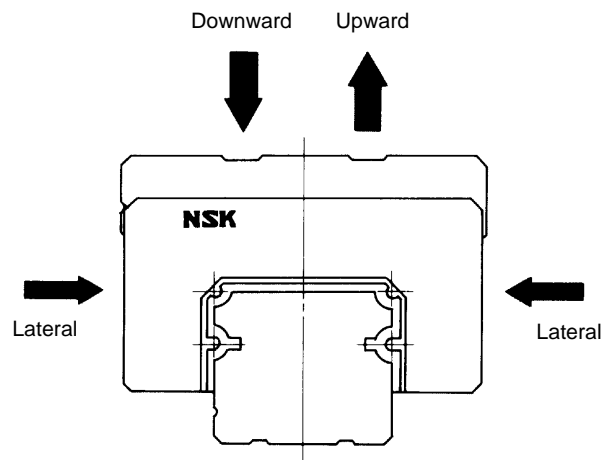

Fig. 5

$$L = 50 \left(\frac{C}{f_w \cdot F} \right)^3$$

where, L : Rated fatigue life(km)

C : Basic dynamic load rating (kgf)

F : Load to a ball slide (kgf)
(Dynamic equivalent load)

f_w : Load factor

$f_w = 1.0 \sim 1.2$ (Smooth condition)

$f_w = 1.2 \sim 1.5$ (Normal condition)

$f_w = 1.5 \sim 3.0$ (With shock or vibration)

LH Series Ball Slide Dimension Table

**REFER TO
PAGES 32 TO 34
REGARDING TECHNICAL
INFORMATION FOR THE
K1 MAINTENANCE-FREE
LUBRICATION SYSTEM**

Square Type

**LAH-AN/ANZ
LAH-BN/BNZ**

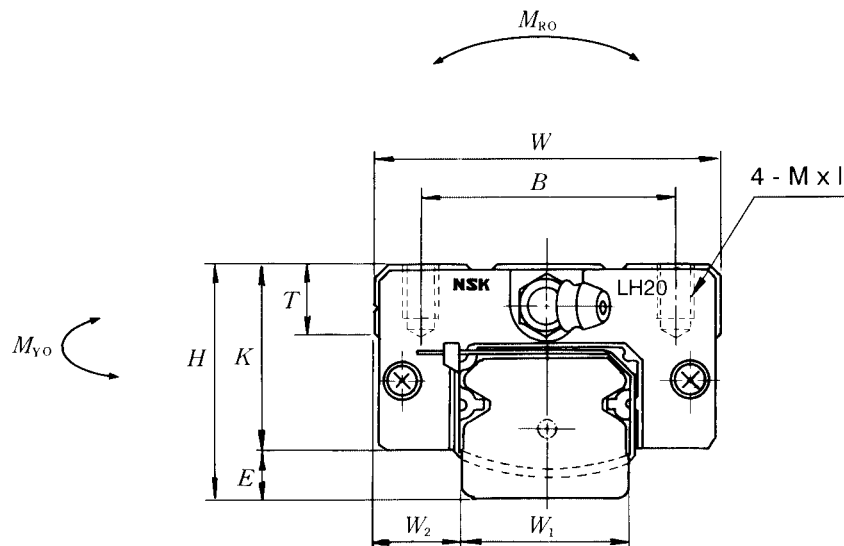

Model No.	Ass'y Dimensions			Ball Slide Dimensions								
	H	E	W ₂	W	B	L	L ₁	J	J ₁	K	T	M x l
LAH15 AN/ANZ	28	4.6	9.5	34	26	55	39	26	6.5	23.4	8	M 4 x 6
LAH20 AN/ANZ LAH20 BN/BNZ	30	5	12	44	32	69.8 91.8	50 72	36 50	7 11	25	12	M 5 x 6
LAH25 AN/ANZ LAH25 BN/BNZ	40	7	12.5	48	35	79 107	58 86	35 50	11.5 18	33	12	M 6 x 9
LAH30 AN/ANZ LAH30 BN/BNZ	45	9	16	60	40	85.6 124.6	59 98	40 60	9.5 19	36	14	M 8 x 10
LAH35 AN/ANZ LAH35 BN/BNZ	55	9.5	18	70	50	109 143	80 114	50 72	15 21	45.5	15	M 8 x 12
LAH45 AN/ANZ LAH45 BN/BNZ	70	14	20.5	86	60	139 171	105 137	60 80	22.5 28.5	56	17	M10 x 17
LAH55 AN/ANZ LAH55 BN/BNZ	80	15	23.5	100	75	163 201	126 164	75 95	25.5 34.5	65	18	M12 x 18
LAH65 AN/ANZ LAH65 BN/BNZ	90	16	31.5	126	76	193 253	147 207	70 120	38.5 48.5	74	23	M16 x 20

Note: W₁ rail dimensions are on Page 12.

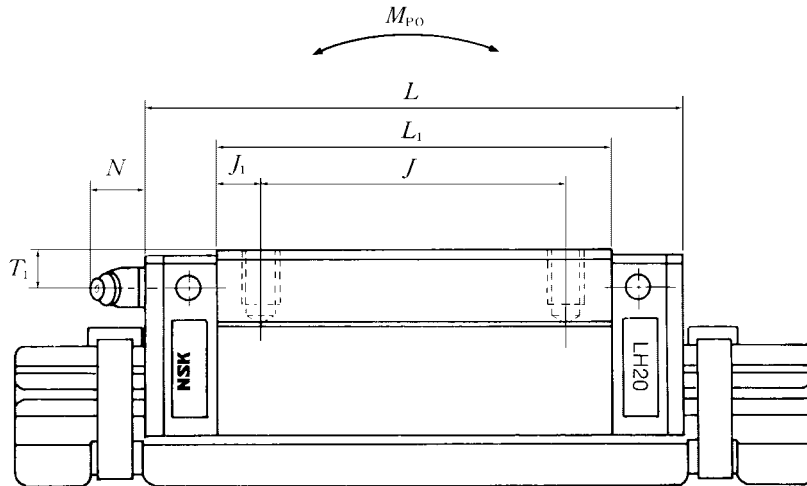

Unit : mm

Grease Fitting			Basic Load Ratings					Weight (kgf)	Model No.
Mounting Hole Thread Spec.	T_1	N	Dynamic C (kgf)	Static C_0 (kgf)	Static Moment (kgf·m)				
					M_{RO}	M_{PO}	M_{VO}		
Ø3 (thru hole)	8.5	3.3	850	1650	10	8	8	0.18	LAH15 AN/ANZ
M6x0.75	5	11	1450	2560	22	18	18	0.33	LAH20 AN/ANZ
			1860	4020	31	35	35	0.48	LAH20 BN/BNZ
M6x0.75	10	11	2140	4000	36	32	31	0.55	LAH25 AN/ANZ
			2740	5340	48	54	53	0.82	LAH25 BN/BNZ
M6x0.75	10	11	2620	4570	50	36	36	0.77	LAH30 AN/ANZ
			3800	7310	80	86	85	1.3	LAH30 BN/BNZ
M6x0.75	15	11	3960	7010	96	75	73	1.5	LAH35 AN/ANZ
			5060	9930	136	144	141	2.1	LAH35 BN/BNZ
PT1/8	20	13	6740	12100	216	170	168	3	LAH45 AN/ANZ
			8130	14900	264	251	248	3.9	LAH45 BN/BNZ
PT1/8	21	13	9940	17100	367	293	288	4.7	LAH55 AN/ANZ
			12000	21100	449	435	426	6.1	LAH55 BN/BNZ
PT1/8	19	13	15100	24500	629	495	484	7.7	LAH65 AN/ANZ
			19300	32700	834	850	830	10.8	LAH65 BN/BNZ

LH Series Ball Slide Dimension Table

**REFER TO
PAGES 32 TO 34
REGARDING TECHNICAL
INFORMATION FOR THE
K1 MAINTENANCE-FREE
LUBRICATION SYSTEM**

Flange Type

LAH-EL/ELZ
LAH-FL/FLZ

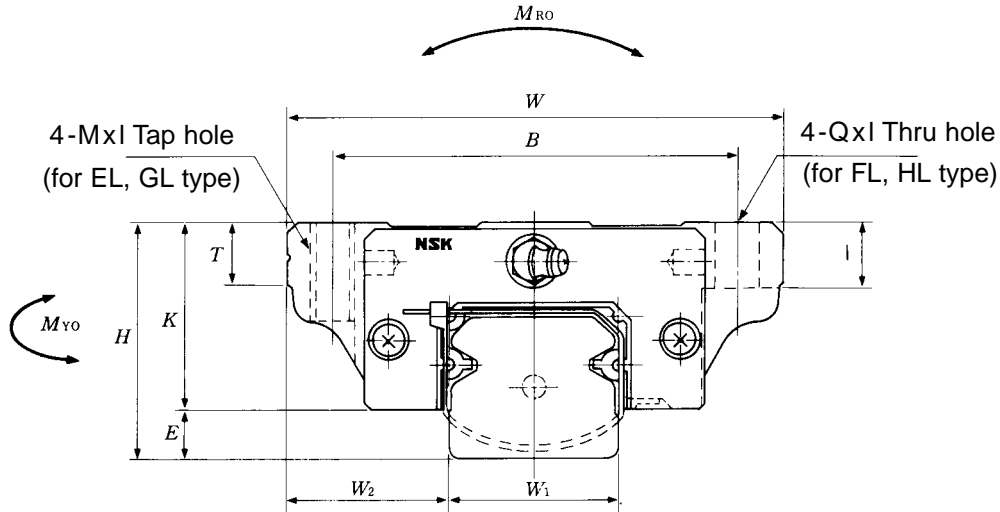

Model No.	Ass'y Dimensions			Ball Slide Dimensions									
	H	E	W ₂	W	B	L	L ₁	J	J ₁	K	T	M x I Q x I	Bolt Size Thru Hole Q
LAH20 EL/ELZ FL/FLZ GL/GLZ HL/HLZ	30	5	21.5	63	53	69.8	50	40	5	25	10	M 6 x 10 6 x 10	M5
LAH20 GL/GLZ HL/HLZ						91.8	72		16				
LAH25 EL/ELZ FL/FLZ GL/GLZ HL/HLZ	36	7	23.5	70	57	79	58	45	6.5	29	11	M 8 x 16 7 x 10	M6
LAH25 GL/GLZ HL/HLZ						107	86		20.5				
LAH30 EL/ELZ FL/FLZ GL/GLZ HL/HLZ	42	9	31	90	72	98.6	72	52	10	33	11	M10 x 18 9 x 12	M8
LAH30 GL/GLZ HL/HLZ						124.6	98		23				
LAH35 EL/ELZ FL/FLZ GL/GLZ HL/HLZ	48	9.5	33	100	82	109	80	62	9	38.5	12	M10 x 20 9 x 13	M8
LAH35 GL/GLZ HL/HLZ						143	114		26				
LAH45 EL/ELZ FL/FLZ GL/GLZ HL/HLZ	60	14	37.5	120	100	139	105	80	12.5	46	13	M12 x 24 11 x 15	M10
LAH45 GL/GLZ HL/HLZ						171	137		28.5				
LAH55 EL/ELZ FL/FLZ GL/GLZ HL/HLZ	70	15	43.5	140	116	163	126	95	15.5	55	15	M14 x 28 14 x 18	M12
LAH55 GL/GLZ HL/HLZ						201	164		34.5				
LAH65 EL/ELZ FL/FLZ GL/GLZ HL/HLZ	90	16	53.5	170	142	193	147	110	18.5	74	23	M16 x 24 16 x 24	M14
LAH65 GL/GLZ HL/HLZ						253	207		48.5				

Note : W₁ rail dimensions are on Page 12.

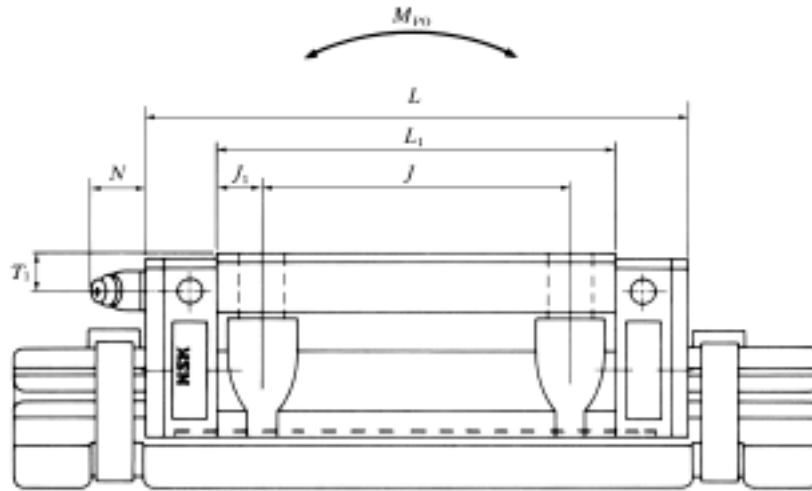

Unit : mm

Grease Fitting			Basic Load Ratings					Weight (kgf)	Model No.
Mounting Hole Thread Spec.	T_1	N	Dynamic C (kgf)	Static Co (kgf)	Static Moment (kgf·m)				
					MRO	MPO	MVO		
M6x0.75	5	11	1450	2560	22	18	18	0.45	LAH20 EL/ELZ FL/FLZ
			1860	4020	31	35	35	0.65	LAH20 GL/GLZ HL/HLZ
M6x0.75	6	11	2140	4000	36	32	31	0.63	LAH25 EL/ELZ FL/FLZ
			2740	5340	48	54	53	0.93	LAH25 GL/GLZ HL/HLZ
M6x0.75	7	11	2980	5490	60	50	49	1.2	LAH30 EL/ELZ FL/FLZ
			3800	7310	80	86	85	1.6	LAH30 GL/GLZ HL/HLZ
M6x0.75	8	11	3960	7010	96	75	73	1.7	LAH35 EL/ELZ FL/FLZ
			5060	9930	136	144	141	2.4	LAH35 GL/GLZ HL/HLZ
PT1/8	10	13	6740	12100	216	170	168	3	LAH45 EL/ELZ FL/FLZ
			8130	14900	264	251	248	3.9	LAH45 GL/GLZ HL/HLZ
PT1/8	11	13	9940	17100	367	293	288	5	LAH55 EL/ELZ FL/FLZ
			12000	21100	449	435	426	6.5	LAH55 GL/GLZ HL/HLZ
PT1/8	19	13	15100	24500	629	495	484	10	LAH65 EL/ELZ FL/FLZ
			19300	32700	834	850	830	14.1	LAH65 GL/GLZ HL/HLZ

LH Series Ball Slide Dimension Table

**REFER TO
PAGES 32 TO 34
REGARDING TECHNICAL
INFORMATION FOR THE
K1 MAINTENANCE-FREE
LUBRICATION SYSTEM**

Flange Type

LAH-EM/EMZ
 (formerly EL-ELZ-90)
LAH-GM/GMZ
 (formerly GL-GLZ-90)

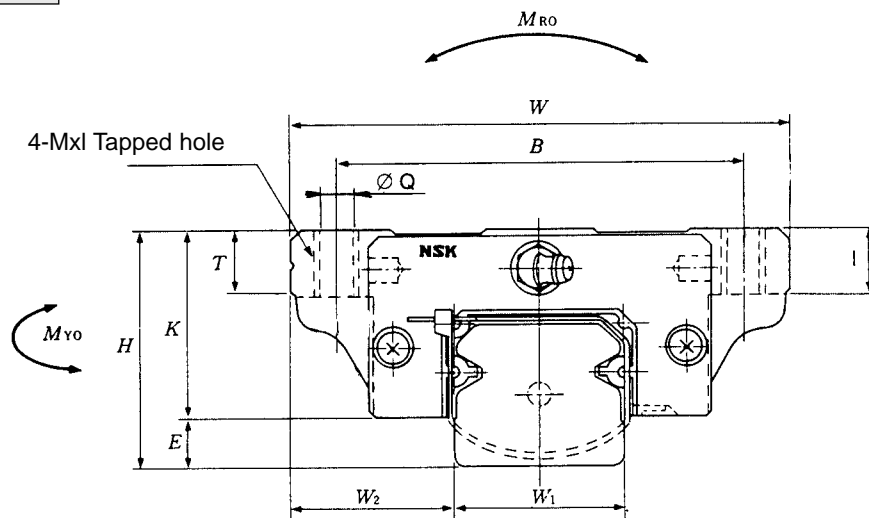

Note: EM/EMZ and GM/GMZ is a combination of Tapped hole and Thru hole.

Model No.	Ass'y Dimensions			Ball Slide Dimensions									
	H	E	W ₂	W	B X J	L	L ₁	J ₁	K	T	M x I	Ø Q x I	Bolt Size Thru Hole Q
LAH15 EM/EMZ GM/GMZ	24	4.6	16	47	38 x 30	55 74	39 58	4.5 14	19.4	8	M5 x 8	Ø4.4 x 8	M4
LAH20 EM/EMZ GM/GMZ	30	5	21.5	63	53 x 40	69.8 91.8	50 72	5 16	25	10	M6 x 10	Ø5.3 x 10	M5
LAH25 EM/EMZ GM/GMZ	36	7	23.5	70	57 x 45	79 107	58 86	6.5 20.5	29	11	M8 x 10	Ø6.8 x 10	M6
LAH30 EM/EMZ GM/GMZ	42	9	31	90	72 x 52	98.6 124.6	72 98	10 23	33	11	M10 x 12	Ø8.6 x 12	M8
LAH35 EM/EMZ GM/GMZ	48	9.5	33	100	82 x 62	109 143	80 114	9 26	38.5	12	M10 x 13	Ø8.6 x 13	M8
LAH45 EM/EMZ GM/GMZ	60	14	37.5	120	100 x 80	139 171	105 137	12.5 28.5	46	13	M12 x 15	Ø10.5 x 15	M10
LAH55 EM/EMZ GM/GMZ	70	15	43.5	140	116 x 95	163 201	126 164	15.5 34.5	55	15	M14 x 18	Ø12.5 x 18	M12
LAH65 EM/EMZ GM/GMZ	90	16	53.5	170	142 x 110	193 253	147 207	18.5 48.5	74	23	M16 x 24	Ø14.6 x 24	M14

Note : W₁ rail dimensions are on Page 12.

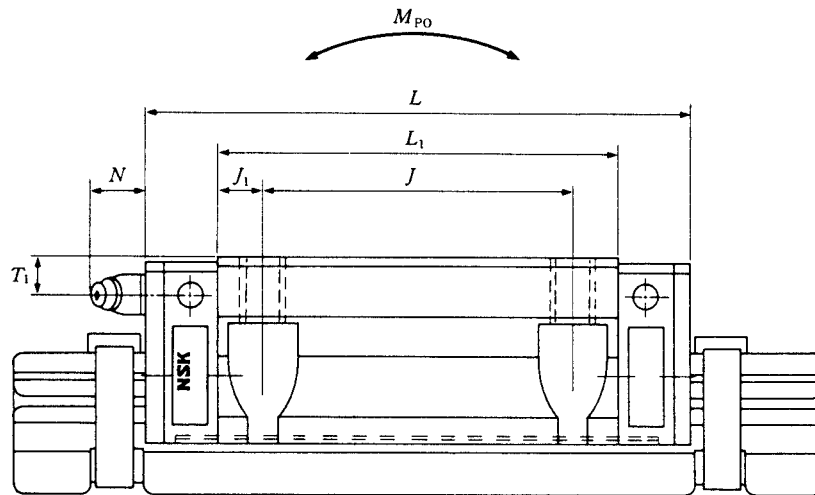

Unit : mm

Grease Fitting			Basic Load Ratings					Weight (kgf)	Model No.
Mounting Hole Thread Spec.	T_1	N	Dynamic C (kgf)	Static Co (kgf)	Static Moment (kgf·m)				
					MRO	MPO	MYO		
Ø3 (thru hole)	4.5	3.3	850	1650	10	8	8	0.17	LAH15 EM/EMZ GM/GMZ
			1140	2550	15	18	18		
M6x0.75	5	11	1450	2560	22	18	18	0.45	LAH20 EM/EMZ GM/GMZ
			1860	4020	31	35	35		
M6x0.75	6	11	2140	4000	36	32	31	0.63	LAH25 EM/EMZ GM/GMZ
			2740	5340	48	54	53		
M6x0.75	7	11	2980	5490	60	50	49	1.2	LAH30 EM/EMZ GM/GMZ
			3800	7310	80	86	85		
M6x0.75	8	11.5	3960	7010	96	75	73	1.7	LAH35 EM/EMZ GM/GMZ
			5060	9930	136	144	141		
PT1/8	10	13	6740	12100	216	170	168	3	LAH45 EM/EMZ GM/GMZ
			8130	14900	264	251	248		
PT1/8	11	13	9940	17100	367	293	288	5	LAH55 EM/EMZ GM/GMZ
			12000	21100	449	435	426		
PT1/8	19	13	15100	24500	629	495	484	10	LAH65 EM/EMZ GM/GMZ
			19300	32700	834	850	830		

LH Series Rail Dimension Table

Separately Sold Rail for NSK Linear Guide

LH series Standard Rail

- L1H : Clearance Interchangeable Type
- L1H-Z : Preloaded Interchangeable Type

LH series Butting Rail

- L1H-01 : Clearance Interchangeable Type
- L1H-01Z : Preloaded Interchangeable Type

LH series butting rail features higher precision tolerances for L_0 and G dimensions.

L1H 25 1200 - 01 Z F

Rail Type

Size No.

Rail Length (mm)

No Code: Standard

F: Fluoride Black Chrome Plating

No Code: Clearance Type

Z: Preloaded Type

No Code: Standard

01: Butting Rail

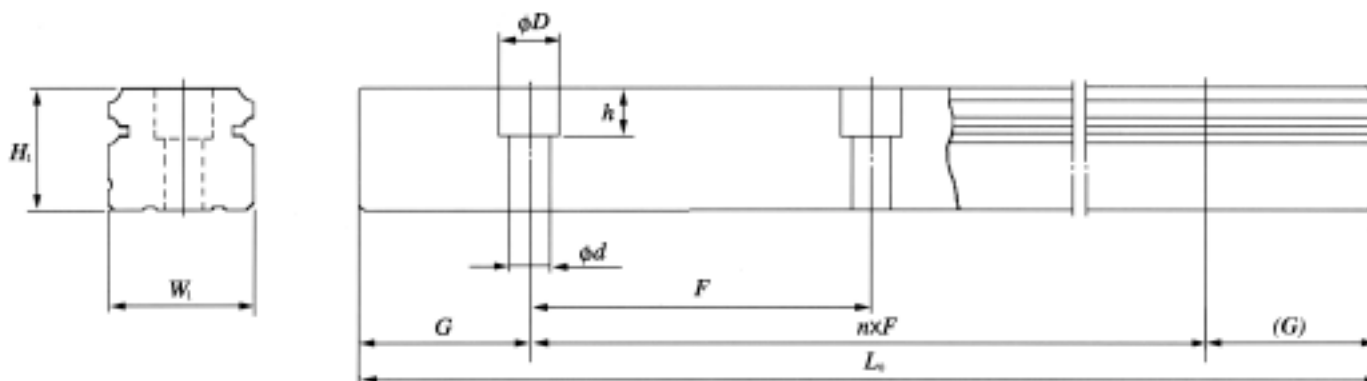

Rail Dimensions Table

Unit: mm

1 mm = 3.937×10^{-2} inch
1kgf/m = $6,721 \times 10^{-1}$ Ft/Lb

Model No.		Max. length L_0	Standard L_0 Butting L_0	W_1	H_1	F	$d \times D \times h$	Rail		Rail Weight (kgf/m)
Standard	Butting							Butting	$G_{-0.5}^0$	
L1H15	L1H15-01	1440	1440	15	15	60	4.5 x 7.5 x 5.3	30		1.6
L1H15-Z	L1H15-01Z									
L1H20	L1H20-01	3960	3960	20	18	60	6 x 9.5 x 8.5	30		2.6
L1H20-Z	L1H20-01Z									
L1H25	L1H25-01	3960	3960	23	22	60	7 x 11 x 9	30		3.6
L1H25-Z	L1H25-01Z									
L1H30	L1H30-01	4000	4000	28	26	80	9 x 14 x 12	40		5.2
L1H30-Z	L1H30-01Z									
L1H35	L1H35-01	4000	4000	34	29	80	9 x 14 x 12	40		7.2
L1H35-Z	L1H35-01Z									
L1H45	L1H45-01	3990	3990	45	38	105	14 x 20 x 17	52.5		12.3
L1H45-Z	L1H45-01Z									
L1H55	L1H55-01	3960	3960	53	44	120	16 x 23 x 20	60		16.9
L1H55-Z	L1H55-01Z									
L1H65	L1H65-01	3900	3900	63	53	150	18 x 26 x 22	75		24.3
L1H65-Z	L1H65-01Z									

Cut to length rails $G = F/2$ ($^{+0}_{-3mm}$)

LH Series Accessories

Protector and Double Seal

Travel length is reduced by the thickness of the end seal on the ball slide. Consider the value of V in the table below when calculating the travel length.

Protector Seal

Unit : mm

Linear Guide Model No.	Protector No. Plug End	Protector No. Grease Fitting End	Increased Thickness V_1
LH15	LH15PT-01	LH15PTC-01	2.7
LH20	LH20PT-01	LH20PTC-01	2.9
LH25	LH25PT-01	LH25PTC-01	3.2
LH30	LH30PT-01	LH30PTC-01	4.2
LH35	LH35PT-01	LH35PTC-01	4.2
LH45	LH45PT-01	LH45PTC-01	4.9
LH55	LH55PT-01	LH55PTC-01	4.9
LH65	LH65PT-01	LH65PTC-01	5.5

One of each PT and PTC is required to do one linear bearing.

Fig. 8 Protector and Double Seal

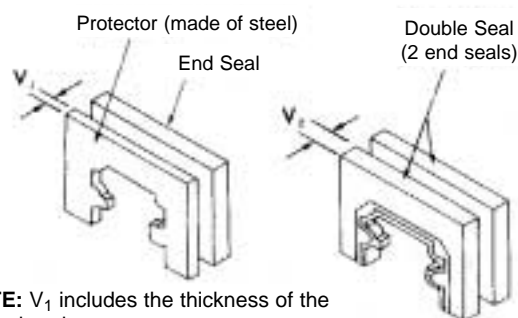

NOTE: V_1 includes the thickness of the screw head.

Adapters

These parts connect piping to the tapped hole when the grease fitting is removed.

Fig. 6 LF Type

For LH20, 25
LH30, 35

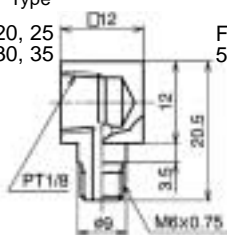

Reference No.:
L80206021-301

For LH45, 55, 65



Reference No.:
L80200029-302

Fig. 7 SF Type

For LH20, 25
LH30, 35

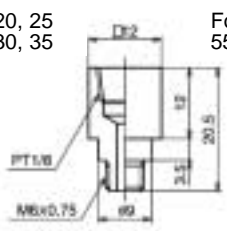

Reference No.:
L80106021-301

For LH45, 55, 65



Reference No.:
L80100025-301

Double Seal

Unit : mm

Linear Guide Model No.	Double Seal No. Plug End	Double Seal No. Grease Fitting End	Increased Thickness V_2
LH15	LH15WS-01	LH15WSC-01	2.5
LH20	LH20WS-01	LH20WSC-01	2.5
LH25	LH25WS-01	LH25WSC-01	2.8
LH30	LH30WS-01	LH30WSC-01	3.6
LH35	LH35WS-01	LH35WSC-01	3.6
LH45	LH45WS-01	LH45WSC-01	4.3
LH55	LH55WS-01	LH55WSC-01	4.3
LH65	LH65WS-01	LH65WSC-01	4.9

One of each WS and WSC is required to do one linear bearing.

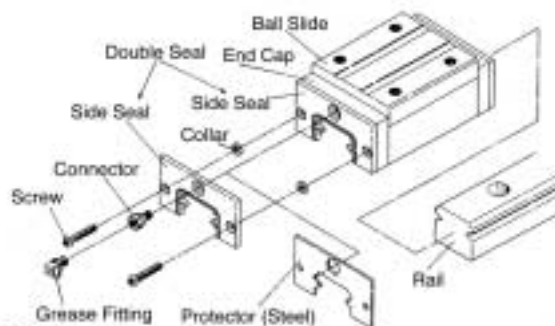

Fig. 13

***NOTE:** - The protector (steel) is always ahead of the side or double seal.

Plastic Cap for Rail Mounting Hole

Linear Guide Model No.	Rail Mounting Bolt Size	Cap. No. for Rail Mounting Hole
LH15	M4	L45800004-003
LH20	M5	L45800005-003
LH25	M6	L45800006-003
LH30	M8	L45800008-003
LH35		
LH45	M12	L45800012-003
LH55	M14	L45800014-003
LH65	M16	L45800016-003

Brass Cap for Rail Mounting Hole

Linear Guide Model No.	Rail Mounting Bolt Size	Cap. No. for Rail Mounting Hole
LH20	M5	L45800005-004
LH25	M6	L45800006-004
LH30	M8	L45800008-004
LH35		
LH45	M12	L45800012-004

LS Series

Identification Number

Refer to the following numbering system when ordering.

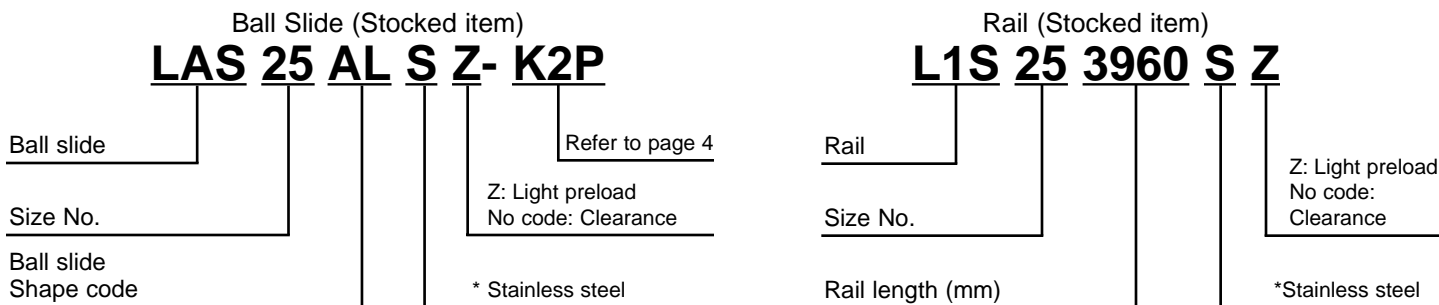

- Flanged Type —
 - LS-EL (High Load) with 4 Tapped Holes
 - LS-FL (High Load) with 4 Thru Holes
 - LS-KL (Medium Load) with 2 Thru Holes
 - Square Type —
 - LS-AL (High Load) with 4 Tapped Holes
 - LS-CL (Medium Load) with 2 Tapped Holes
- Both types have stainless steel series.

Fig.-1 LS-AL, LS-CL

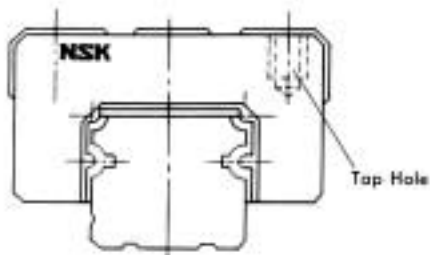
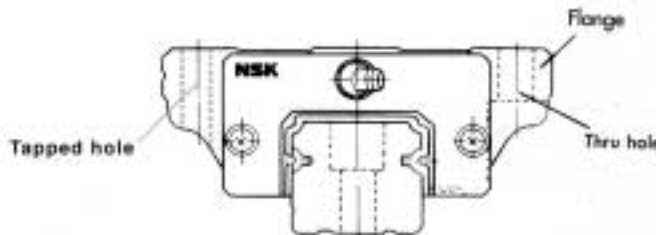

Fig.-2 LS-EL, LS-FL, LS-KL



Radial Clearance and Preload

The clearance when interchangeable rail and ball slide components are combined is as listed in Table 2. Minus symbol indicates the preload.

Unit: μm

Model No.	Clearance	Light Preload Z
LS15	15~-4	0~-4
LS20	15~-4	0~-4
LS25	15~-5	0~-5
LS30	15~-5	0~-5
LS35	15~-5	0~-6

*Consult NSK for price and delivery.

Accuracy Standard

The accuracy standard of the NSK "Compact Low Profile LS-Series" is shown in Table 1. With high-accuracy control of individual rail size and interchangeability, the accuracy of Table 1 can be maintained sufficiently even after addition or replacement of the ball slide.

Table 1 Tolerances		Unit : μm
Tolerances (See Fig. 4 for Symbols)		Model No. LS
		15, 20, 25, 30, 35
Clearance Type	Overall Height, H	± 20
	Lateral Width, W_2	± 30
Preload Type	Overall Height, H	± 20
	Lateral Width, W_2	± 30
Running Parallelism of Face [C] to Face [A]		Refer to Fig. 4
Running Parallelism of Face [D] to Face [B]		

W_2 is applicable to the reference side only. Note during installation the reference side is indicated by a line provided on the side of ball slide and rail. (See Fig. 4)

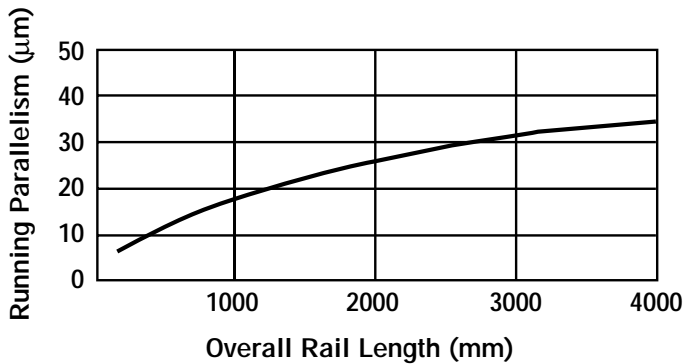

Fig. 3 Running Parallelism

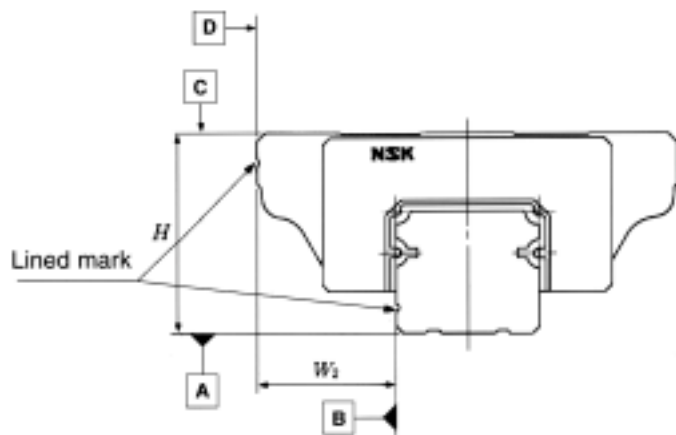

Fig. 4 Accuracy Standard

Load Rating and Life

The LS-Series is based on a design applying load from above. Therefore the dimension table shows the basic dynamic load rating C and basic static load rating C_0 for the downward direction. If the load is applied laterally or upward refer to values in Table 2.

Table 2 Basic Load Rating Correction for Direction

Load Direction	Basic Dynamic Load Rating	Basic Static Load Rating
Downward	C	C_0
Upward	C	$0.75C_0$
Laterally	$0.88C$	$0.63C_0$

Estimate the life of linear guides using the equation below.

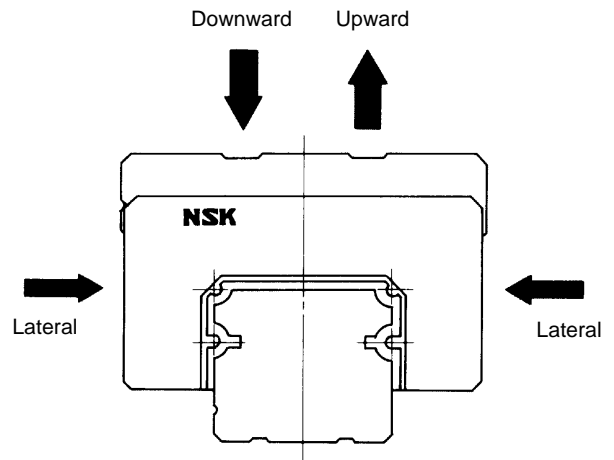

Fig. 5

$$L = 50 \left(\frac{C}{f_w \cdot F} \right)^3$$

where, L : Rated fatigue life(km)

C : Basic dynamic load rating (kgf)

F : Load to a ball slide (kgf)
(Dynamic equivalent load)

f_w : Load factor

$f_w = 1.0 \sim 1.2$ (Smooth condition)

$f_w = 1.2 \sim 1.5$ (Normal condition)

$f_w = 1.5 \sim 3.0$ (With shock or vibration)

LS Series Ball Slide Dimension Table

**REFER TO
PAGES 32 TO 34
REGARDING TECHNICAL
INFORMATION FOR THE
K1 MAINTENANCE-FREE
LUBRICATION SYSTEM**

Square Type

- LAS-CL (Z) : Standard Steel**
- LAS-AL (Z) :**
- LAS-CLS (Z) : Stainless Steel**
- LAS-ALS (Z) :**

Note: Consult NSK for price and delivery on stainless steel.

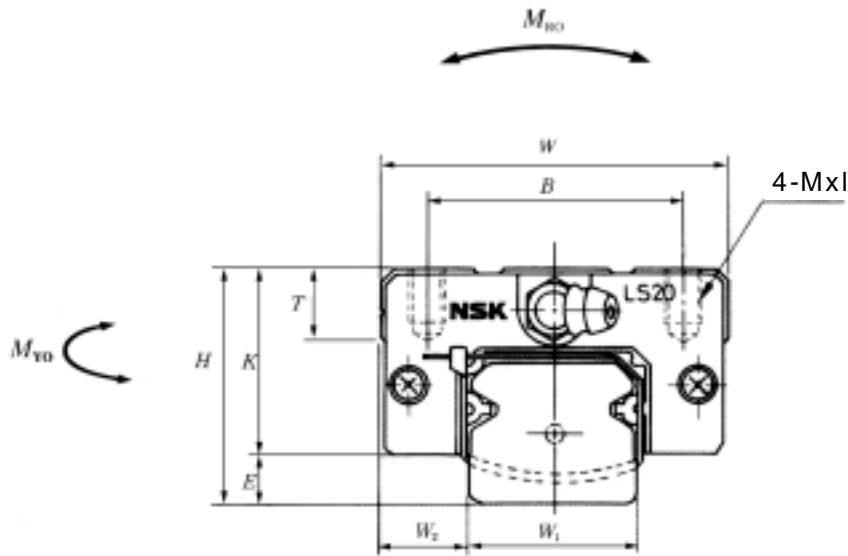

Model No.	Ass'y Dimensions			Ball Slide Dimensions								
	H	E	W_2	W	B	L	L_1	J	J_1	K	T	$M \times I$
LAS15 CL/CLZ LAS15 AL/ALZ	24	4.6	9.5	34	26	40.4 56.8	23.6 40	— 26	11.8 7	19.4	10	M 4 x 6
LAS20 CL/CLZ LAS20 AL/ALZ	28	6	11	42	32	47.2 65.2	30 48	— 32	15 8	22	12	M 5 x 7
LAS25 CL/CLZ LAS25 AL/ALZ	33	7	12.5	48	35	59.6 81.6	38 60	— 35	19 12.5	26	12	M 6 x 9
LAS30 CL/CLZ LAS30 AL/ALZ	42	9	16	60	40	67.4 96.4	42 71	— 40	21 15.5	33	13	M 8 x 12
LAS35 CL/CLZ LAS35 AL/ALZ	48	10.5	18	70	50	77 108	49 80	— 50	24.5 15	37.5	14	M 8 x 12

Note: W_1 rail dimensions are on Page 20.

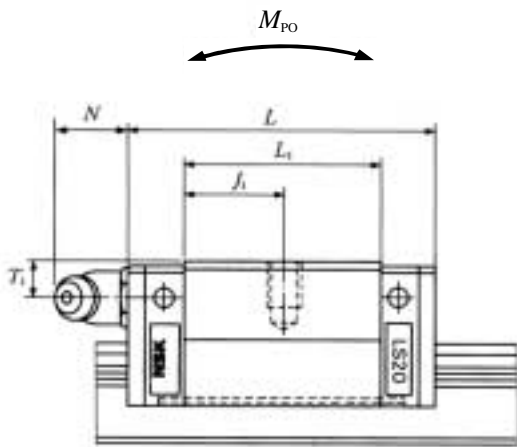

LAS-CL/CLZ

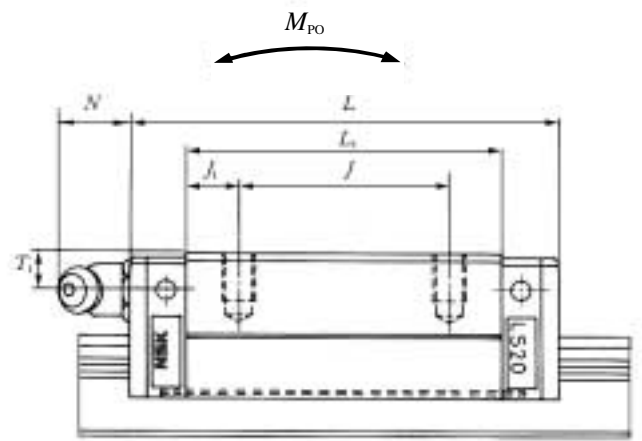

LAS-AL/ALZ

Unit : mm

Grease Fitting			Basic Load Ratings					Weight (kgf)	Model No.
Mounting Hole Thread Spec.	T_1	N	Dynamic C (kgf)	Static C_0 (kgf)	Static Moment (kgf•m)				
					M_{RO}	M_{PO}	M_{YO}		
Ø3 (Thru Hole)	6	3	465	845	4	2	2	0.14	LAS15 CL/CLZ LAS15 AL/ALZ
			685	1270	7	5	5	0.20	
M6x0.75	5.5	11	670	1240	9	4	4	0.19	LAS20 CL/CLZ LAS20 AL/ALZ
			910	1780	13	9	9	0.28	
M6x0.75	7	11	1080	1900	14	7	7	0.34	LAS25 CL/CLZ LAS25 AL/ALZ
			1470	2970	25	21	20	0.51	
M6x0.75	8	11	1620	2700	25	11	11	0.58	LAS30 CL/CLZ LAS30 AL/ALZ
			2390	4400	48	36	36	0.85	
M6x0.75	8.5	11	2250	3650	42	18	18	0.86	LAS35 CL/CLZ LAS35 AL/ALZ
			3320	5940	79	58	57	1.25	



LS Series Ball Slide Dimension Table

**REFER TO
PAGES 32 TO 34
REGARDING TECHNICAL
INFORMATION FOR THE
K1 MAINTENANCE-FREE
LUBRICATION SYSTEM**

Flange Type

LAS-KL (Z) : Standard Steel
LAS-FL (Z) :
LAS-EL (Z) :
LAS-KLS (Z) : Stainless Steel
LAS-KLS (Z) :

Note: Consult NSK for price and delivery on stainless steel.

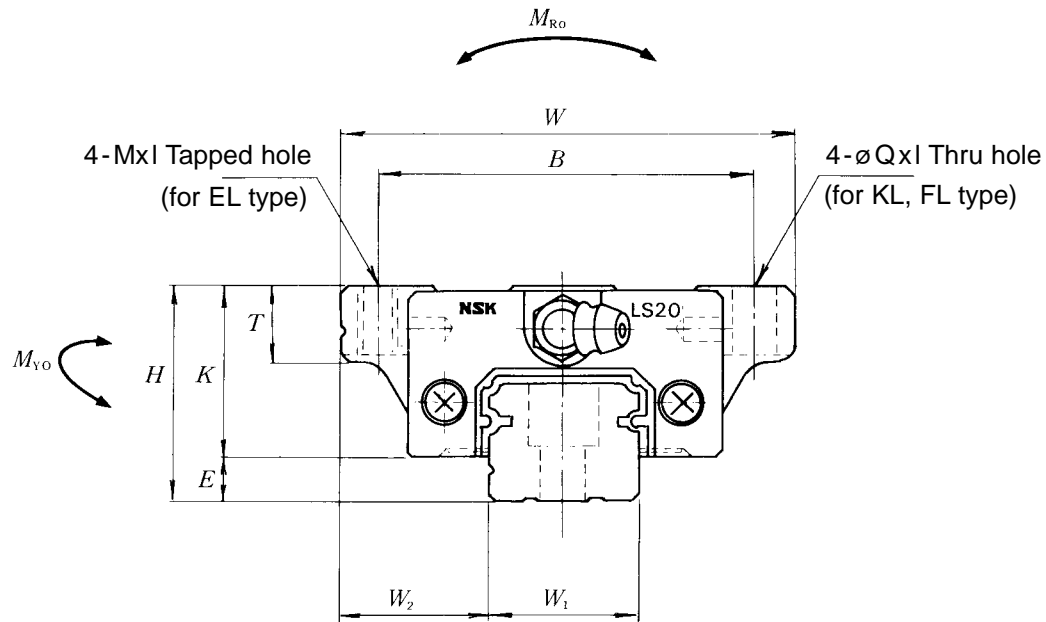

Model No.	Ass'y Dimensions			Ball Slide Dimensions									Bolt Size Thru Hole Q		
	H	E	W ₂	W	B x J	L	L ₁	J ₁	K	T	Q x I	M x I			
LAS15 KL/KLZ	24	4.6	18.5	52	41	40.4	23.6	11.8	19.4	8	4.5 x 7	M 5 x 8	M4		
LAS15 FL/FLZ					41 x 26	56.8	40	7						4.5 x 7	M4
LAS15 EL/ELZ					41 x 26	56.8	40	7							
LAS20 KL/KLZ	28	6	19.5	59	49	47.2	30	15	22	10	5.5 x 9	M 6 x 10	M5		
LAS20 FL/FLZ					49 x 32	65.2	48	8			5.5 x 9			M5	
LAS20 EL/ELZ					49 x 32	65.2	48	8							
LAS25 KL/KLZ	33	7	25	73	60	59.6	38	19	26	11	7 x 10	M 8 x 12	M6		
LAS25 FL/FLZ					60 x 35	81.6	60	12.5			7 x 10			M6	
LAS25 EL/ELZ					60 x 35	81.6	60	12.5							
LAS30 KL/KLZ	42	9	31	90	72	67.4	42	21	33	11	9 x 12	M 10 x 18	M8		
LAS30 FL/FLZ					72 x 40	96.4	71	15.5			9 x 12			M8	
LAS30 EL/ELZ					72 x 40	96.4	71	15.5							
LAS35 KL/KLZ	48	10.5	33	100	80	77	49	24.5	37.5	12	9 x 13	M 10 x 20	M8		
LAS35 FL/FLZ					82 x 50	108	80	15			9 x 13			M8	
LAS35 EL/ELZ					82 x 50	108	80	15							

Note: W₁ rail dimensions are on Page 20.

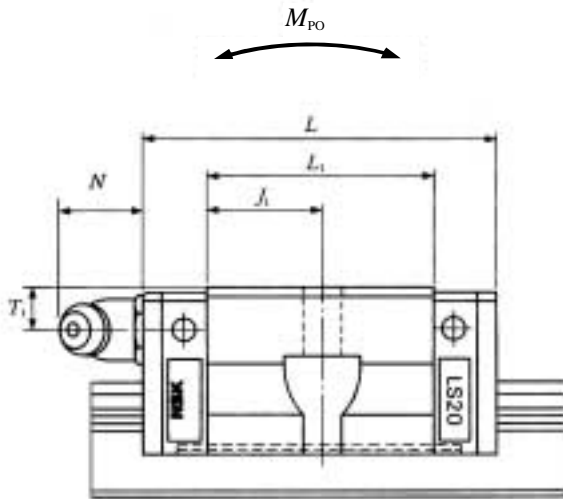

LAS-KL/KLZ

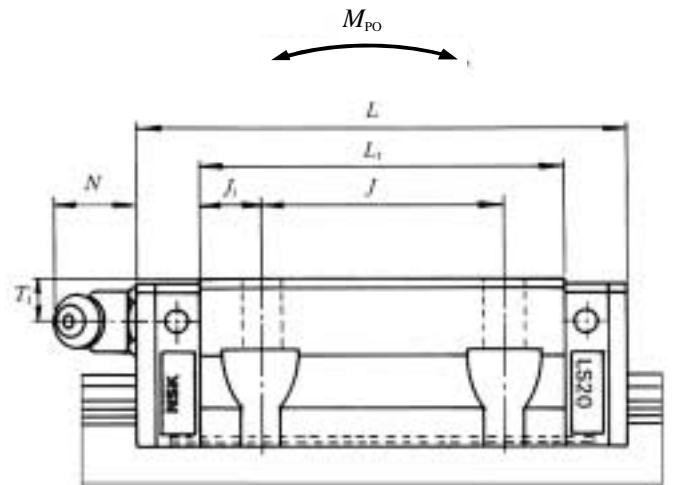

**LAS-FL/FLZ
LAS-EL/ELZ**

Unit : mm

Grease Fitting			Basic Load Ratings					Weight (kgf)	Model No.
Mounting Hole Thread Spec.	T_1	N	Dynamic C (kgf)	Static C_0 (kgf)	Static Moment (kgf·m)				
					M_{RO}	M_{PO}	M_{YO}		
Ø3 (Thru Hole)	6	3	465	845	4	2	2	0.17	LAS15 KL/KLZ LAS15 FL/FLZ LAS15 EL/ELZ
			685	1270	7	5	5	0.26	
			685	1270	7	5	5	0.26	
M6x0.75	5.5	11	670	1240	9	4	4	0.24	LAS20 KL/KLZ LAS20 FL/FLZ LAS20 EL/ELZ
			910	1780	13	9	9	0.35	
			910	1780	13	9	9	0.35	
M6x0.75	7	11	1080	1900	14	7	7	0.44	LAS25 KL/KLZ LAS25 FL/FLZ LAS25 EL/ELZ
			1470	2970	25	21	20	0.66	
			1470	2970	25	21	20	0.66	
M6x0.75	8	11	1620	2700	25	11	11	0.76	LAS30 KL/KLZ LAS30 FL/FLZ LAS30 EL/ELZ
			2390	4400	48	36	36	1.2	
			2390	4400	48	36	36	1.2	
M6x0.75	8.5	11	2250	3650	42	18	18	1.2	LAS35 KL/KLZ LAS35 FL/FLZ LAS35 EL/ELZ
			3320	5940	79	58	57	1.7	
			3320	5940	79	58	57	1.7	

LS Series Rail Dimension Table

Separately Sold Rail for NSK Linear Guide

LS series Standard Rail

L1S : Clearance Interchangeable Type

L1S-Z : Preloaded Interchangeable Type

Identification Number

Rail

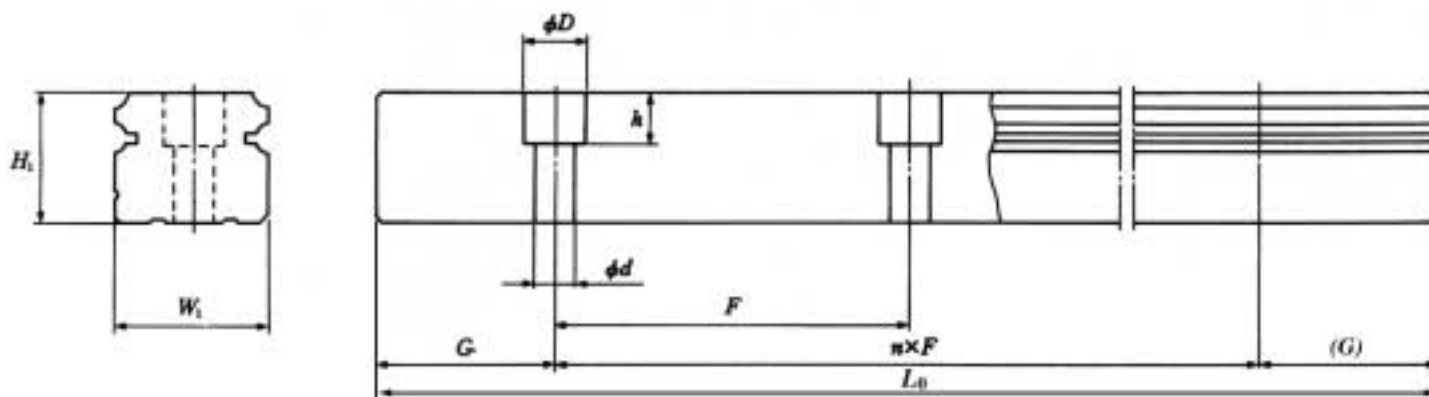
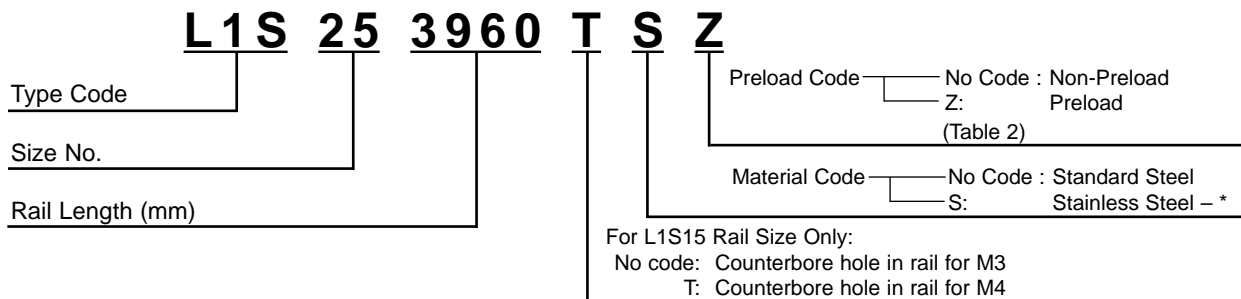

Model No.	Rail Dimensions						
	Weight W_1	H_i	Pitch F	Bolt Hole $d \times D \times H$	G Recommended	Max. rail length L_0 max. () indicates Stainless Steel	Weight Rail (kgf/m)
L1S15	15	12.5	60	3.5x6x4.5	20	1600 (1000)	1.4
L1S15T	15	12.5	60	4.5x7.5x5.3	20	1600 (1000)	1.4
L1S20	20	15.5	60	6x9.5x8.5	30	3960 (3500)	2.3
L1S25	23	18	60	7x11x9	30	3960 (3500)	3.1
L1S30	28	23	80	7x11x9	40	4000 (3500)	4.8
L1S35	34	27.5	80	9x14x12	40	4000 (3500)	7.0

Cut to length rails $G = F/2$ ($^{+0}_{-4mm}$)

* Consult NSK for price and delivery.

LS Series Accessories

Protector and Double Seal

Travel length is reduced by the thickness of the end seal on the ball slide. Consider the value of V in the table below when calculating the travel length.

Protector Seal

Unit : mm

Linear Guide Model No.	Protector No. Plug End	Protector No. Grease Fitting End	Increased Thickness V_1
LS15	LS15PT-01	LS15PTC-01	3.0
LS20	LS20PT-01	LS20PTC-01	2.7
LS25	LS25PT-01	LS25PTC-01	3.2
LS30	LS30PT-01	LS30PTC-01	4.2
LS35	LS35PT-01	LS35PTC-01	4.2

One of each PT and PTC is required to do one linear bearing.

Double Seal

Unit : mm

Linear Guide Model No.	Double Seal No. Plug End	Double Seal No. Grease Fitting End	Increased Thickness V_2
LS15	LS15WS-01	LS15WSC-01	2.8
LS20	LS20WS-01	LS20WSC-01	2.5
LS25	LS25WS-01	LS25WSC-01	2.8
LS30	LS30WS-01	LS30WSC-01	3.6
LS35	LS35WS-01	LS35WSC-01	3.6

One of each WS and WSC is required to do one linear bearing.

Fig. 7 Protector and Double Seal

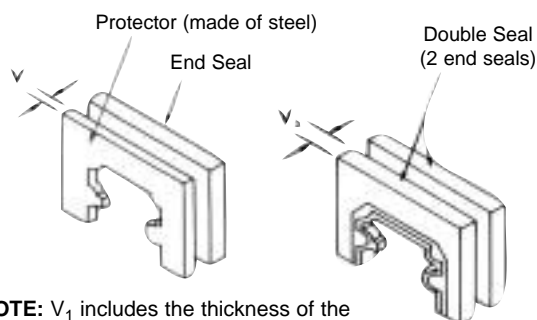

NOTE: V_1 includes the thickness of the screw head.

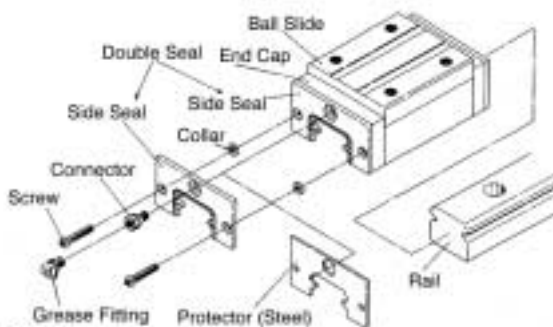

Fig. 13

***NOTE:** - The protector (steel) is always ahead of the side or double seal.

Adapter

These parts connect piping to the tapped hole when the grease fitting is removed.

Fig. 5 LF Type

Adapter No. L80206021-301

For LS20, 25
LS30, 35

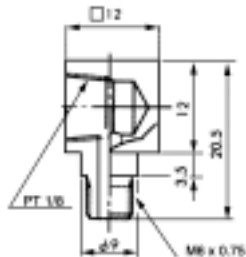

Fig. 6 SF Type

Adapter No. L80106021-301

For LS20, 25
LS30, 35

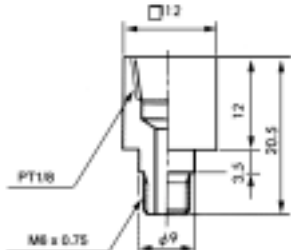

Table 12 Cap for Rail Mounting Hole

Linear Guide Model No.	Rail Mounting Bolt Size	Cap. No. for Rail Mounting Hole
LS15	M3	L45800003-003
LS20	M5	L45800005-003
LS25	M6	L45800006-003
LS30		
LS35	M8	L45800008-003

Brass Cap for Rail Mounting Hole

Linear Guide Model No.	Rail Mounting Bolt Size	Cap. No. for Rail Mounting Hole
LS20	M5	L45800005-004
LS25	M6	L45800006-004
LS30		
LS35	M8	L45800008-004

LU Series

Identification Number

Refer to the following numbering system when ordering.

REFER TO
PAGES 32 TO 34
REGARDING
TECHNICAL
INFORMATION FOR
THE K1
MAINTENANCE-FREE
LUBRICATION SYSTEM

Ball Slide (Stocked item)
LAU 12 AR S

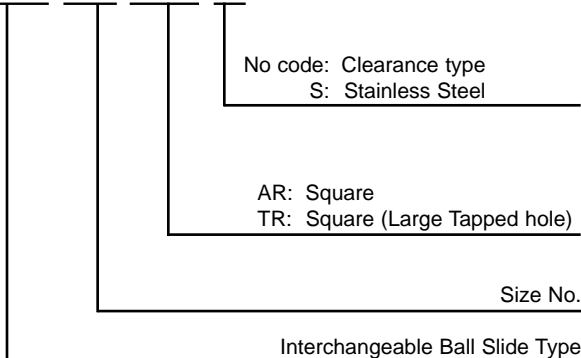

Rail (Stocked item)
L1U 12 0120 T S

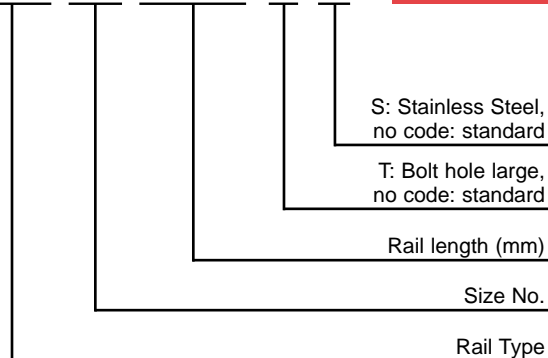

Ball Slide

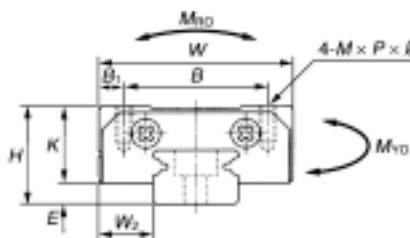

LU series ball slide dimension

Unit: mm

Model No.	Assembly Dimension			Ball Slide Dimensions									Basic Load Rating			Weight (gf)		
	Height <i>H</i>	<i>E</i>	Width <i>W₂</i>	Length <i>W</i>	<i>L</i>	<i>B</i>	Tapped Hole			<i>L₁</i>	<i>J₁</i>	<i>K</i>	Dynamic <i>C</i> (kgf)	Static <i>C₀</i> (kgf)	Static Moment (kgf•m)			
							<i>J</i>	Thread <i>M x P x l</i>	<i>B₁</i>						<i>M_{RO}</i>		<i>M_{PO}</i>	<i>M_{YO}</i>
LAU09ARS LAU09TRS	10	2.2	5.5	20	30	15	13	M2 x 0.4 x 2.5	2.5	20	3.5	7.8	120	180	0.9	0.5	0.5	19
LAU12ARS LAU12TRS	13	3	7.5	27	35.2	20	15	M2.5 x 0.45 x 3 M3 x 0.5 x 3.5	3.5	21.8	3.4	10	220	250	2.2	1.2	38	38
LAU15ALS	16	4	8.5	32	43.6	25	20	M3 x 0.5 x 4	3.5	27	3.5	12	440	460	4.3	2.2	2.2	70

Rail

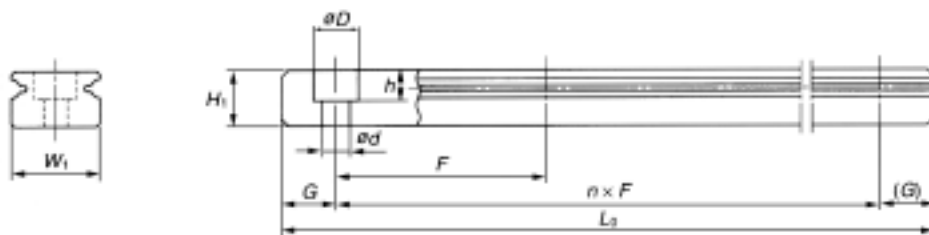

LU series rail dimension

Unit: mm

Model No.	Standard Length (in stock)				Rail Dimension					Weight (gf/100mm)	
					Width <i>W₁</i>	Length <i>H₁</i>	Bolt pitch <i>F</i>	Bolt hole <i>d x D x h</i>	<i>G</i> (Standard)		Rail length <i>L_{0 max}</i>
L1U09*S L1U09*TS	115	195	275		9	5.5	20	2.6 x 4.5 x 3 3.5 x 6 x 4.5	7.5	275	35
L1U12*S L1U12*TS	170	270	470	800	12	7.5	25	3 x 5.5 x 3.5 3.5 x 6 x 4.5	10	800	65
L1U15*S	230	430	670	990	15	9.5	40	3.5 x 6 x 4.5	15	1000 (Stainless: 670)	105

*Stainless Steel

LE Series

Identification Number

Refer to the following numbering system when ordering.

REFER TO
PAGES 32 TO 34
REGARDING
TECHNICAL
INFORMATION FOR
THE K1
MAINTENANCE-FREE
LUBRICATION SYSTEM

Ball Slide (Stocked item)

LAE 12 AR S

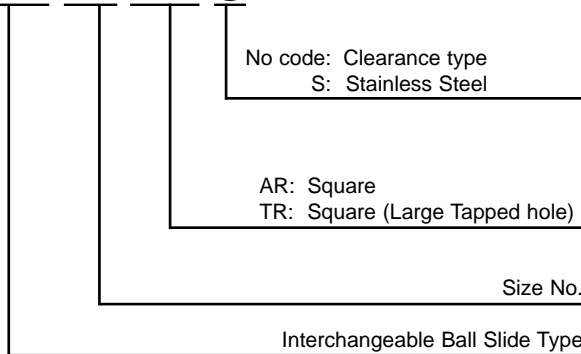

Rail (Stocked item)

L1E 12 0120 S

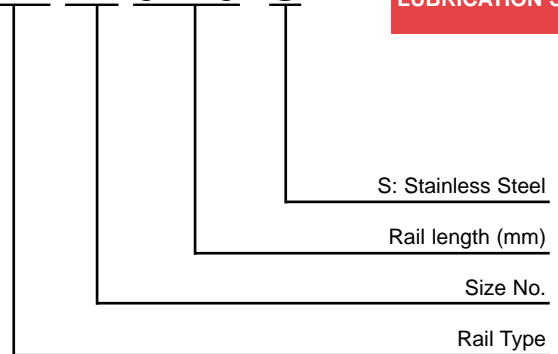

Ball Slide

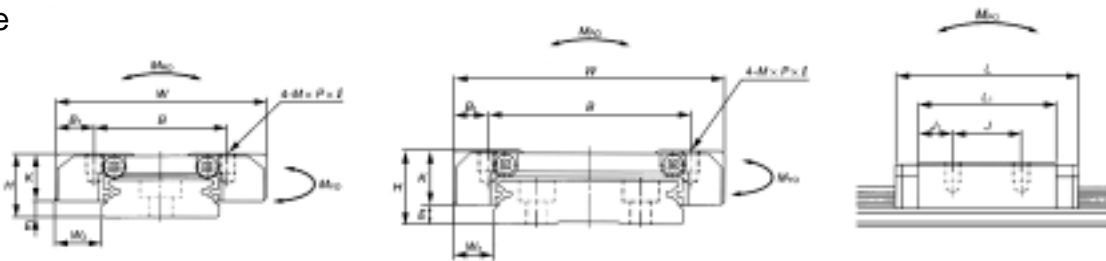

LE series ball slide dimension

Unit: mm

Model No.	Assembly Dimension			Ball Slide Dimensions									Basic Load Rating			Weight (gf)		
	Height <i>H</i>	<i>E</i>	<i>W</i> ₂	Width <i>W</i>	Length <i>L</i>	<i>B</i>	Tapped Hole			<i>L</i> ₁	<i>J</i> ₁	<i>K</i>	Dynamic <i>C</i> (kgf)	Static <i>C</i> ₀ (kgf)	Static Moment (kgf·m)			
							<i>J</i>	Thread <i>M x P x l</i>	<i>B</i> ₁						<i>M</i> _{RO}		<i>M</i> _{PO}	<i>M</i> _{VO}
LAE09ARS LAE09TRS	12	4	6	30	39.8	21	12	M2.6 x 0.45 x 3 M3 x 0.5 x 3	4.5	27.6	7.8	8	250	380	3.3	1.7	1.7	40
LAE12ARS	14	4	8	40	45	28	15	M3 x 0.5 x 4	6.0	31	8	10	360	540	6.0	2.4	2.4	75
LAE15ARS	16	4	9	60	56.6	45	20	M4 x 0.7 x 4.5	7.5	38.4	9.2	12	630	890	17.7	4.9	4.9	150

Rail

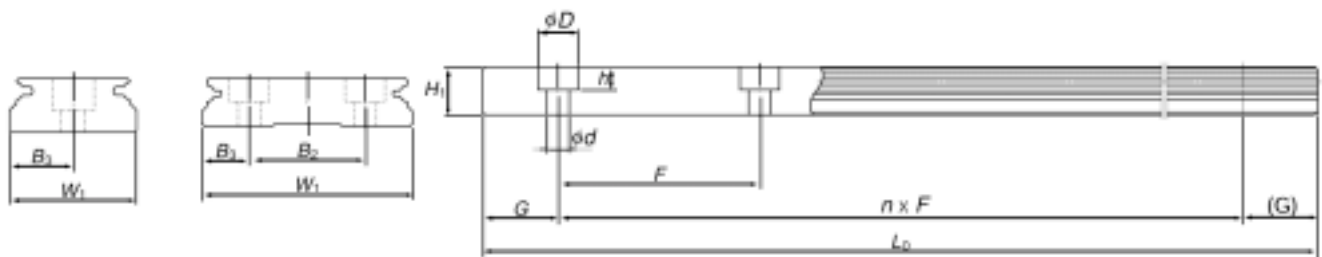

LE series rail dimension

Unit: mm

Model No.	Standard Length (in stock)				Rail Dimension									Weight (gf/100mm)
					Width <i>W</i> ₁	Length <i>H</i> ₁	Bolt pitch <i>F</i>	<i>B</i> ₂	<i>B</i> ₃	Bolt hole <i>d x D x h</i>	G hole (Standard)	Rail length <i>L</i> _{0 max}		
L1E09*S	110	200	290	380	18	7.5	30	—	9	3.5 x 6 x 4.5	10	400	95	
L1E12*S	150	310	470	790	24	8.5	40	—	12	4.5 x 8 x 4.5	15	800	140	
L1E15*S	230	430	670	990	42	9.5	40	23	9.5	4.5 x 8 x 4.5	15	1000	275	

*Stainless Steel



LW Series

Identification Number

Refer to the following numbering system when ordering.

REFER TO
PAGES 32 TO 34
REGARDING
TECHNICAL
INFORMATION FOR
THE K1
MAINTENANCE-FREE
LUBRICATION SYSTEM

Ball Slide (Stocked item)

LAW 27 EL Z

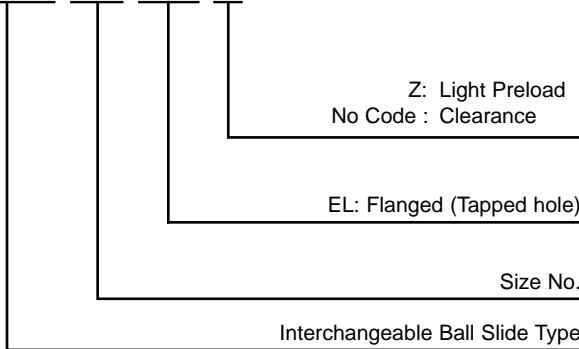

Rail (Stocked item)

L1W 27 0820 Z

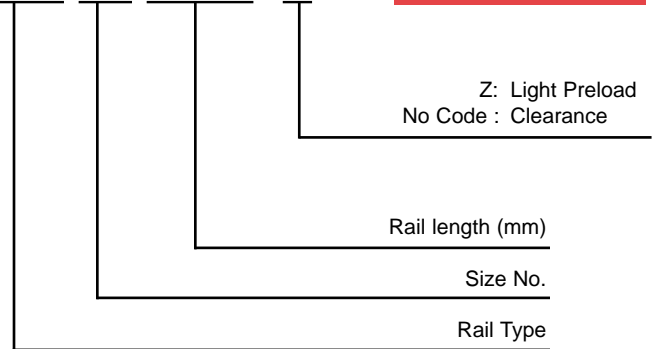

Ball Slide

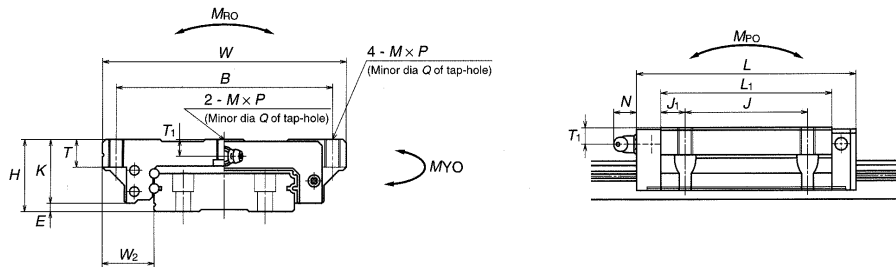

LW series ball slide dimension

Unit: mm

Model No.	Assembly Dimension					Ball Slide Dimensions											Basic Load Rating					Weight (kgf)
	Height H	E	W ₂	Width W	Length L	Tapped Hole				L ₁	J ₁	K	T	Grease fitting			Dynamic C(kgf)	Static C ₀ (kgf)	Static Moment (kgfm)			
						B x J	Thread M x P	T ₁	Q					Thread	T ₁	N			M _{RO}	M _{PO}	M _{YO}	
LAW17EL/ELZ	17	2.5	13.5	60	51.4	53 x 26	M4 x 0.7	3.2	3.3	35	4.5	14.5	6	ø3 thru hole	4	3	430	930	11.6	3.7	3.4	0.2
LAW21EL/ELZ	21	3	15.5	68	58.8	60 x 29	M5 x 0.8	3.7	4.4	41	6	18	8	M6 x 0.75	4.5	11	480	1080	15.0	4.8	4.5	0.3
LAW27EL/ELZ	27	4	19	80	74	70 x 40	M6 x 1	6	5.3	56	8	23	10	M6 x 0.75	6	11	1000	2200	35.6	14.3	13.8	0.5
LAW35EL/ELZ	35	4	25.5	120	108	107 x 60	M8 x 1.25	8	6.8	84	12	31	14	M6 x 0.75	8	11	2620	5340	149.5	54.4	53.3	1.5
LAW50EL/ELZ	50	4.5	36	162	140.6	144 x 80	M10 x 1.5	14	8.6	108	14	45.5	18	PT 1/8	14	14	4840	9350	347.0	128.9	126.2	4.0

Rail

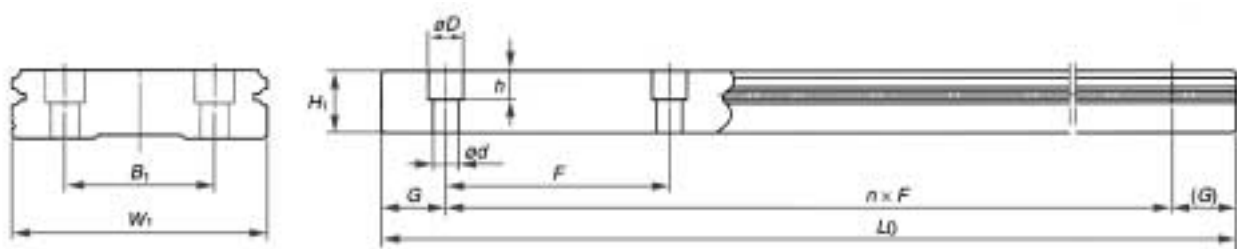

LW series rail dimension

Unit: mm

Model No.	Standard Length (in stock)					Rail Dimension					Weight (kgf/m)		
						Width W ₁	Height H ₁	Bolt pitch F	B ₁	Bolt hole d x D x h		G (Standard)	Rail length L _{0 max}
L1W17	430	670	990			33	8.7	40	18	4.5 x 7.5 x 5.3	15	1000	2.1
L1W21	430	680	980			37	10.5	50	22	4.5 x 7.5 x 5.3	15	1600	2.9
L1W27	460	640	820	1000		42	15	60	24	4.5 x 7.5 x 5.3	20	2000	4.7
L1W35	440	600	760	1000	1240	69	19	80	40	7 x 11 x 9	20	2400	9.6
L1W50	440	600	760	1000	1240	90	24	80	60	9 x 14 x 12	20	3000	15.8

Assembly

Interchangeable ball slides are shipped on (disposable) plastic provisional rails as shown in Fig.-9.

- ① Wipe off anticorrosive oil from the rail.
- ② Since Alvania (AV2) grease is packed in the ball slide, you can use it as delivered.
- ③ Align the rail with bottom and side faces of provisional rail and while pushing the provisional rail lightly against the rail, slide the ball slide on to the rail (Fig.-9).

Fig. -9 Assembly of Ball Slide with Rail

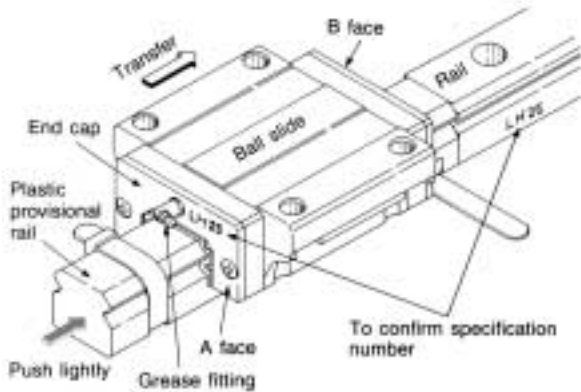

Mounting Method

Shoulder Height and Corner Shape at Mounting Face

When utilizing the reference surface to secure rail or ball slides to machine components the components must have the mounting face height (H' , H'') and corner chamfer (r) dimensions as listed in Table 6 and illustrated in Figs. 10 and 11, to avoid interference.

Table 6 Shoulder height and corner shape at mounting face (LH, LS Series) Unit : mm

Product No.	Radius of corner r (max.)	Shoulder Height of Rail H'	Shoulder Height of Ball Slide H''
15	0.5	4.0	4
20	0.5	4.5	5
25	0.5	5	5
30	0.5	6	6
35	0.5	6	6
45	0.7	8	8
55	0.7	10	10
65	1.0	11	11

Fig. -10 Rail Datum Face Mounting Part

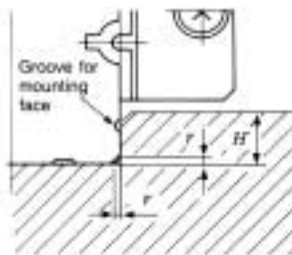
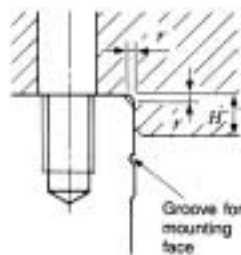

Fig. -11 Ball Slide Datum Face Mounting Part



Mounting Procedure

< For cases where datum surface exists on the bed >

- ① Lightly tighten the rail mounting bolts and then use the shoulder plate to secure rail datum surface against bed mounting surface (See Fig. 12).
- ② Tighten rail mounting bolts to their recommended torques (Table 7). Tighten the bolts in an order which enables the wrench to help push the rail against the mounting surface (see Fig. 13 for example).

Fig. -12 Positioning of Rail

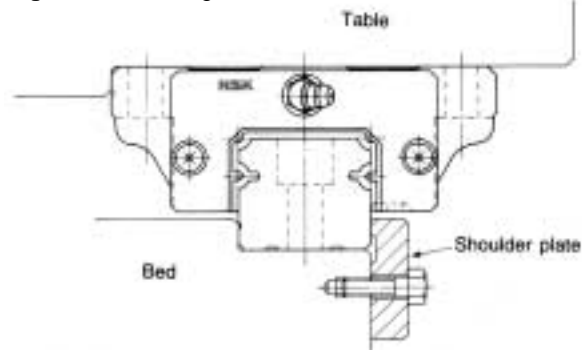
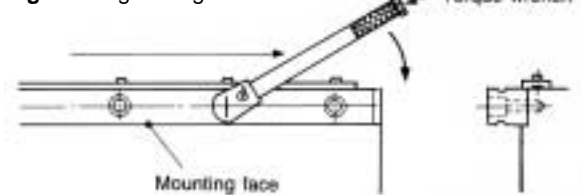

Table 7 Recommended Torque for Rail Mounting Bolt (case of thermally refined bolt) Unit : kgf•cm

Bolt Nominal No.	Torque	Bolt Nominal No.	Torque
M3	10.8	M10	440
M4	25	M12	770
M5	52	M14	1240
M6	88	M16	2000
M8	220		

[1 kgf•cm=0.8681 Lb in]

Fig. -13 Tightening Direction



- ③ Mount the adjust side rail, as shown in Fig.-14, while checking rail parallelism. For the jig shown in Fig.-14, stability will be improved by mounting it on 2 ball slide.

Fig. -14 Parallelism Measurement with Jigs

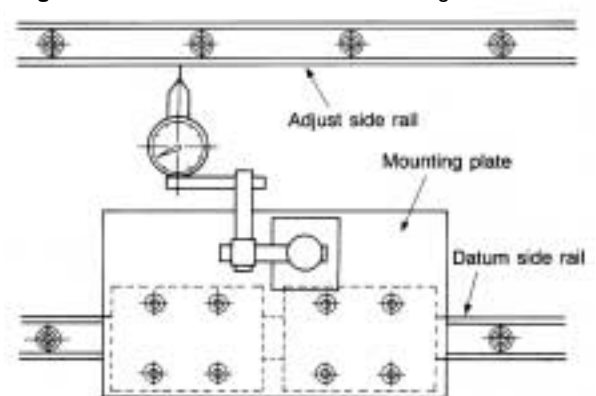

- ④ If dowel pins are being used they should be installed at this step.
- ⑤ Position the ball slides at specified intervals and mount the table gently.
- ⑥ Tighten ball slide mounting bolts of datum side while pushing the table so that the table and ball slide mounting reference surfaces are in contact.

Indication of Installed Standard Side

The datum face of each rail is indicated by a groove in the datum face or by an arrow mark on the end or top surface of the rail.

Model	LU09 LE Series (all models)	LU12,15
High-carbon steel		
Stainless steel		

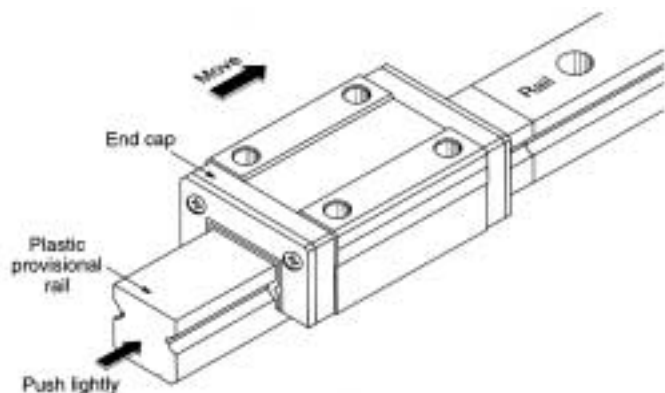

Notes on Usage

Separately packaged ball slide is mounted on a plastic temporary axis (disposable) as shown at left.

- (1) Wipe anti-rust oil from the rail.
- (2) Product is ready for use as is since Alvania 2 grease is sealed inside the ball slide.
- (3) Note the groove mark which identifies the datum faces of ball slide and rail above.
- (4) Move the ball slide, matching and slightly pushing the base and the side of provisional rail to the rail as in drawing at left.

Lubrication

Grease Lubrication

NSK linear guides are packed with Alvania 2 grease and can be used as delivered. The replenishment frequency is recommended to be once a year, but adjust the interval depending on the operation conditions.

(1) To Change Direction of Grease Fitting

- ① Remove the grease fitting with a wrench.
- ② Wind some sealing tape on the thread of the fitting, then insert it and tighten. Be careful not to over torque when tightening into the side of the plastic bearing end cap.

(2) Change of Fitting Position in Front/Back Direction

- ① Remove the plug from the grease fitting mounting hole face B shown in Fig.-9 with a hexagonal wrench.
- ② Remove the grease fitting from face A and screw into hole face B.
- ③ In place of the removed fitting, insert the plug into the hole in the face A.

(3) Change Grease Fitting Position to Side Surface

To mount the grease fitting on the end cap side face, or on the ball slide face, please consult NSK.

Oil Lubrication

Oil piping can be connected to the tapped hole from where the grease fitting was removed. Piping joints are listed on page 13 and page 21. The recommended lubrication oil supply quantity per ball slide per hour Q is given by the following formula, where N is the rail width number.

$$Q = \frac{N}{150} \text{ (ml/hr)} \dots\dots\dots (5)$$

Using LH45 as an example, $N = 45$, and

$$Q = \frac{45}{150} = 0.3 \text{ (ml/hr)}$$

GREASE FITTINGS FOR NSK BALL SLIDES

TYPE	LINEAR GUIDE MODEL #	GREASE FITTING PART #	THREAD SPEC.
DRIVE	LH15, LS15, LW17	L50010000-301	DIA. 3MM
A	LH,LS 20,25,30,35	L50000000-001	M6X0.75MM
B	SAME	L50100000-001	M6X0.75MM
C	SAME PLUS LW21, 27, 35	L50200000-001	M6X0.75MM
A	LH 45, 55, 65	L50003000-001	PT 1/8
B	SAME	L50103000-001	PT 1/8
C	SAME PLUS LW50	L50203000-001	PT 1/8

Fig. -15 Shape of Grease Fitting

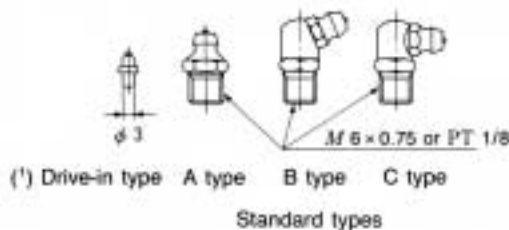

(1) Applies only to model No. LH15, LS15 and LW17.

NSK Grease Unit

Replenish grease to NSK linear guides and ball screws by a manual type hand grease pump. Install the grease in bellows tube to the pump. Several types of grease (80 g) are available.



Grease in a bellows tube



1. Composition of NSK Grease Unit

Components and grease types are shown below.

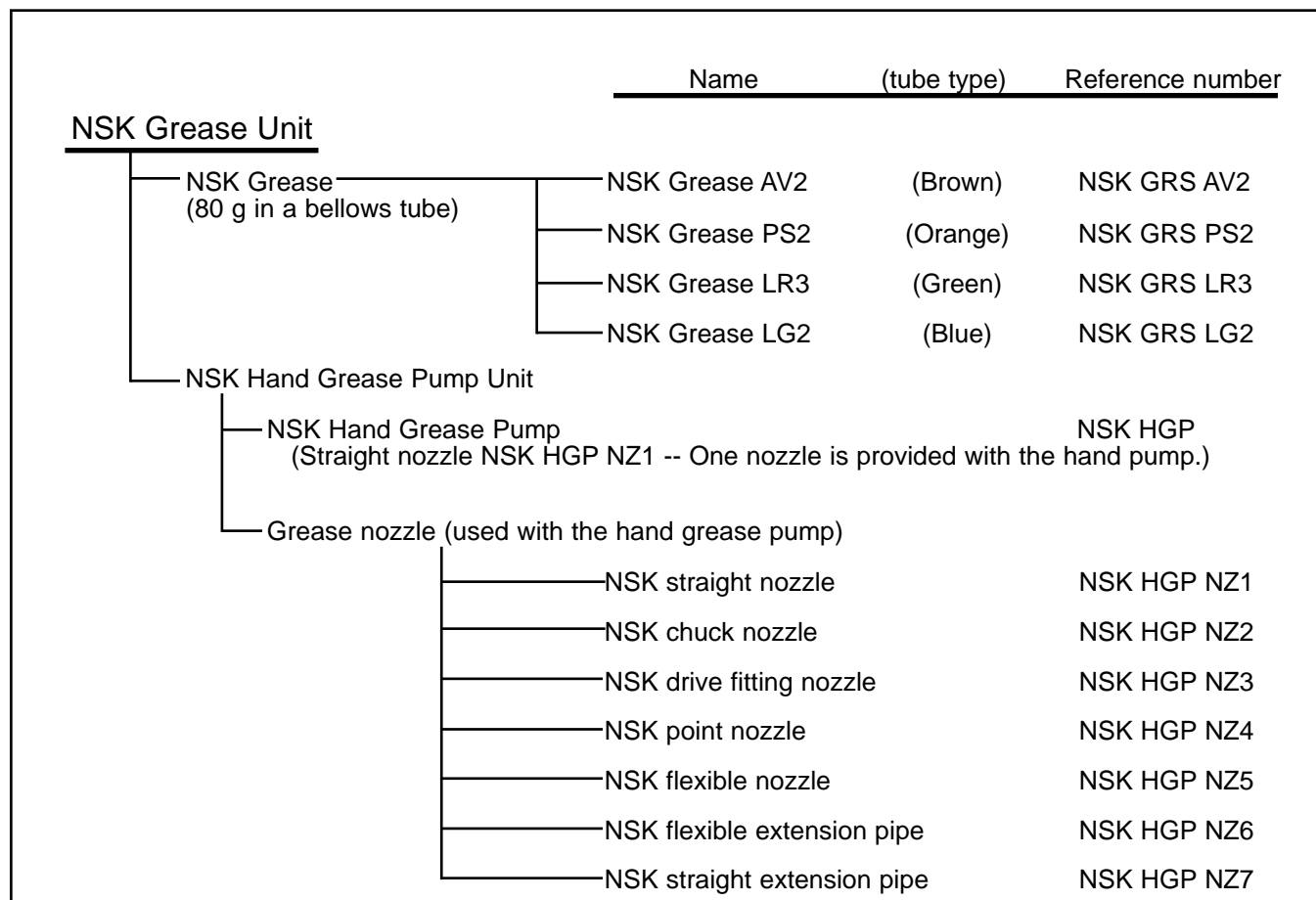

2. NSK Greases (80 g in a bellows tube)

Bellows tube

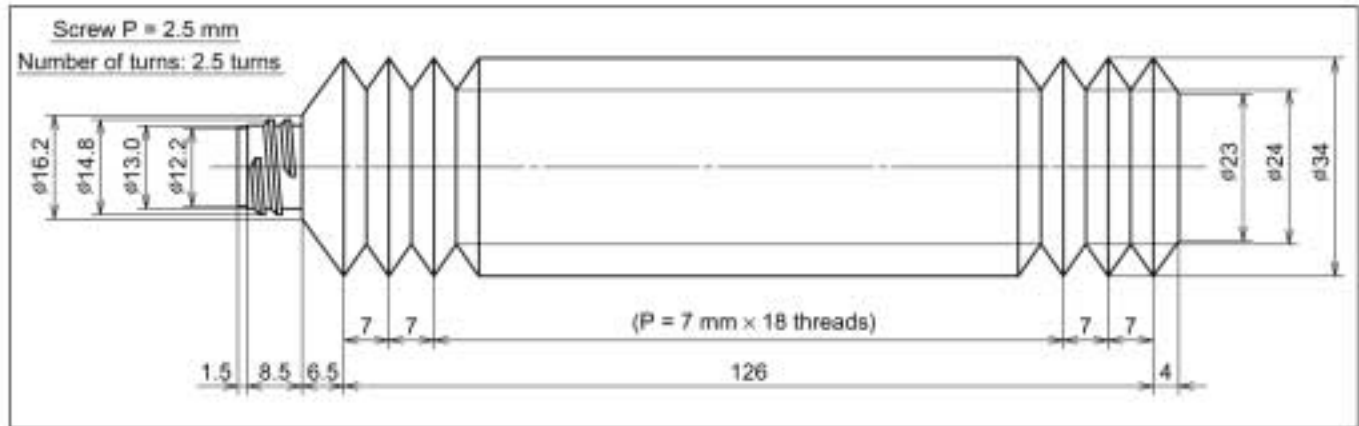

3. NSK manual Grease Pump Unit

(1) NSK Hand Grease Pump Unit (Reference number: NSK HGP)

● Features

- Light-weight ••••• Can be operated by one hand, yet there is no worry to making a mistake.
- Inserting by high pressure •• Insert at 15 Mpa.
- No leaking ••••• Does not leak when held upside down.
- Easy to change grease •• Simply attach the grease in bellows tube.
- Remaining grease •• Can be confirmed through slit on the tube.
- Several nozzles ••••• Five types of nozzles to choose from.

● Specifications

- Spout volume ••••• 0.35 g/stroke
- Mass of main body •• 393 g
- Overall length ••••• About 200 mm
- Overall width ••••• About 200 mm
- Grease tube outer diameter •• φ38.1
- Accessory ••••• Several nozzles for a unique application can be attached

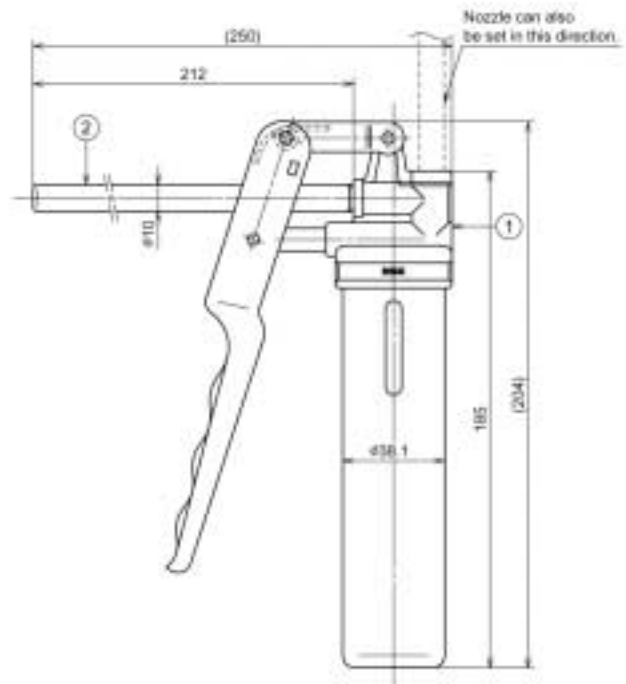

Fig. 2-3 NSK Hand Grease Pump with NSK straight nozzle

(2) Nozzles

Nozzles that can be attached to NSK Hand Grease Pump

Name	Designation code	Use	Dimensions
NSK straight nozzle	NSK HGP NZ1	Can be used with grease fitting A, B, and C under JIS B1575 standard.	
NSK chuck nozzle	NSK HGP NZ2	Same as above. However, there is no need to press the hand pump because the grease fitting and the nozzle come to contact due to the chucking mechanism at the tip.	
NSK fitting nozzle	NSK HGP NZ3	Dedicated for the - f3 drive-in grease fitting.	
NSK point nozzle	NSK HGP NZ4	Used for linear guides and ball screws which do not have grease fitting. Supplies grease directly to the ball grooves, or through the opening of ball slide or ball slide to inside.	
NSK flexible nozzle	NSK HGP NZ5	The tip of the flexible nozzle is chuck nozzle. Used to supply grease to the area where hand cannot reach.	
NSK flexible extension pipe	NSK HGP NZ6	Flexible extension pipe connects the grease pump and the nozzle	
NSK straight extension pipe	NSK HGP NZ7	Straight extension pipe connects the grease pump and the nozzle.	

Grease lubricant for linear guides and ball screws

Type	Thickener	Base oil	Base oil kinematic viscosity cSt (40°C)	Range of use temperature (°C)	Purpose
AV2	Lithium type	Mineral oil	130	-10~110	For ball screws and linear guides for general use at high load.
PS2	Lithium type	Synthetic oil + mineral oil	15	-50~110	For ball screws and linear guides for low temperature and high frequency operation.
LR3	Lithium type	Synthetic oil	30	-30~130	For ball screws at high speed, medium load.
LG2	Lithium type	Synthetic oil + synthetic hydrocarbon oil	30	-10~80	For ball screws and linear guides for clean environment.
NF2	Urea composite type	Synthetic oil + mineral oil	27	-40~100	For fretting resistant ball screws and linear guides.

Table Grease nozzle used for NSK linear guide

Linear guide model	Tap hole for grease fitting	Standard grease fitting	Straight nozzle NZ1	Chuck nozzles (two) NZ	Drive-in nipple nozzle NZ3	Point nozzle NZ4	Flexible nozzle NZ5
LS15	∅ 3	Drive-in type			○		
LS20 ~35	M6 x 0.75	B type	○	○			○
LH15	∅ 3	Drive-in type			○		
LH20 ~35	M6 x 0.75	B type	○	○			○
LH45 ~85	PT1 / 8	B type	○	○			○
LW17	∅ 3	Drive-in type			○		
LW21 ~35	M6 x 0.75	B type	○	○			○
LW50	PT/18	B type	○	○			○
LU09 ~15	-	None				○ ⁽²⁾	
LE09 ~15	-	None				○ ⁽²⁾	

*1) LU and LE Series: Apply grease directly to ball groove, etc. using a point nozzle.

*2) LS20, LS25, LH20: Use straight nozzle. (Point nozzle tip cannot be used because it interferes with the rail top surface.)

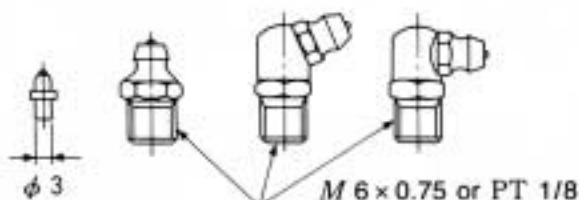

(1) Drive-in type A type B type C type

Figures of Grease fittings

Application Sheet Linear Guides – Rail Butting

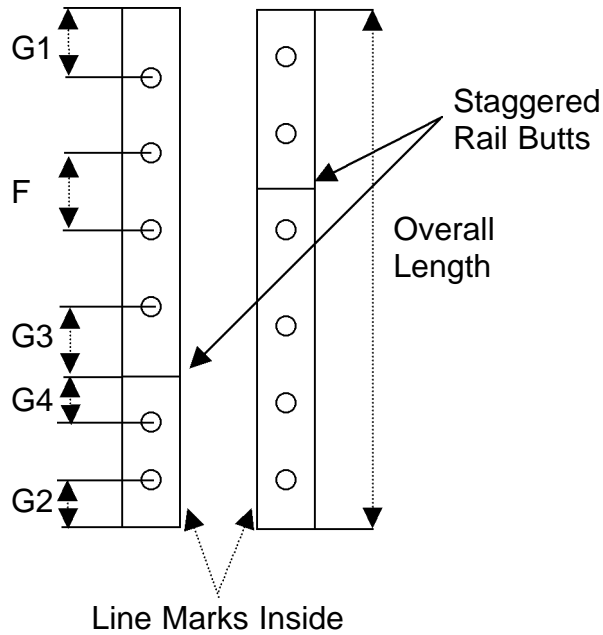

In order to determine rail butting configuration, please photocopy and complete this form from our catalogue and fax back to NSK. An electronic copy is available please contact our customer service.

Quantity _____ Rail Number: _____

G1 Dimension: _____ mm G2 Dimension: _____ mm

F Dimension: _____ mm

Note: Make sure line marks are inside for Rail Butting.

Consists of _____ G1= _____ G3= _____

_____ G2= _____ G4= _____

Company: _____

Contact Name: _____

Telephone: _____ Fax: _____

Date: _____ E-Mail: _____

Remarks: _____

K1 Maintenance-Free Lubrication System

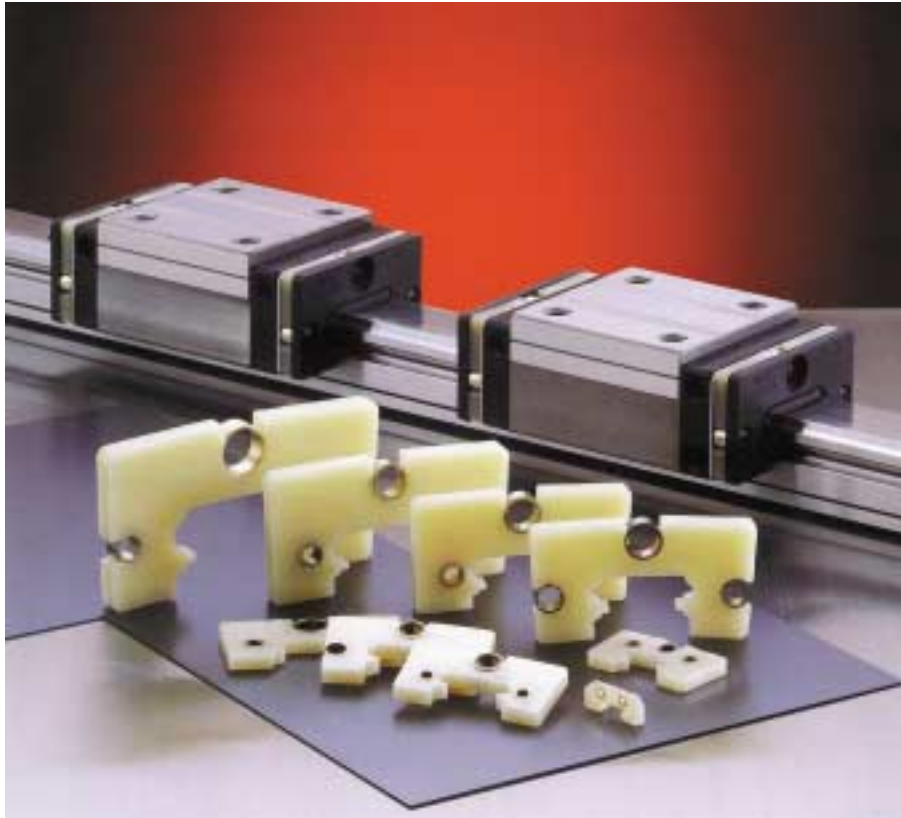

The NSK K1's distinctive capabilities as a compact and efficient oil-impregnated lubrication unit as well as a seal, greatly increases the performance of the Linear Guide. The K1 Lubrication Unit is available in two types, one for industrial applications and one for food and medical devices where cleanliness and safety are paramount.

Features:

1: LONG-TERM, MAINTENANCE-FREE USAGE.

In mechanical environments where lubrication is difficult to apply, long-term running efficiency is maintained by using the NSK K1 in combination with grease.

2: PREVENTION OF OIL-RELATED ENVIRONMENTAL POLLUTION.

In locations where oil greatly affects the environment, or in mechanisms with severe hygiene restrictions, sufficient lubrication is provided using the NSK K1 in combination with grease.

3: EFFECTIVE IN ENVIRONMENTS WHERE THE LUBRICANT IS WASHED AWAY.

In facilities where mechanisms are washed down with water, or subject to severe weather conditions, long service life is ensured by using the NSK K1 in combination with grease. Especially effective under hygienic conditions where oil must not be dispersed.

4: MAINTAINS EFFICIENCY IN DUSTY ENVIRONMENTS.

In environments where oil and grease-absorbing dust is produced, long-term efficiency is maintained by using the NSK K1 in combination with grease.

K1 Identification Number

Refer to the following numbering system when ordering.

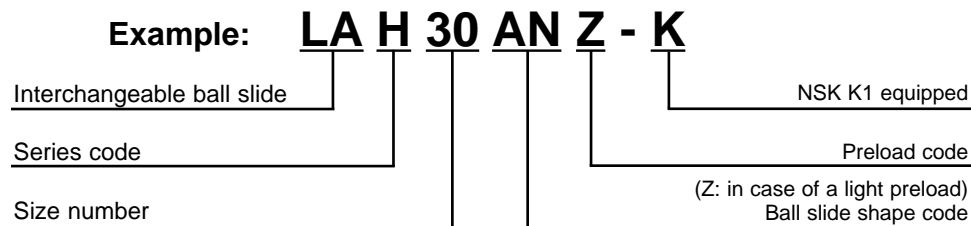

Interchangeable Linear Guide Dimensions – LH, LS, LW, LU, LE Series Unit: mm

Interchangeable Ball Slide size code	Ball slide form			Standard Ball Slide length	Ball slide length with two NSK K1 L	Thickness of NSK K1 V ₁	Thickness of protective cover V ₂	Grease fitting projection N (mm)																																																																																																																																																																																																																																																																							
LAH15	AN	EM		55	65.6	4.5	0.8	(5)																																																																																																																																																																																																																																																																							
		GM		74	84.6				LAH20	AN	EL	FL	69.8	80.4	4.5	0.8	(14)	BN	GL	HL	91.8	102.4	LAH25	AN	EL	FL	79	90.6	5.0	0.8	(14)	BN	GL	HL	107	118.6	LAH30	AN	EL	FL	85.6	97.6	5.0	1.0	(14)	BN	GL	HL	98.6	110.6	LAH35	AN	EL	FL	109	122	5.5	1.0	(14)	BN	GL	HL	143	156	LAH45	AN	EL	FL	139	154	6.5	1.0	(15)	BN	GL	HL	171	186	LAH55	AN	EL	FL	163	178	6.5	1.0	(15)	BN	GL	HL	201	216	LAH65**	AN	EL	FL	193	211	8.0	1.0	(16)	BN	GL	HL	253	271	LAS15	AL	EL	FL	56.8	66.4	4.0	0.8	(5)	CL		KL	40.4	50	LAS20	AL	EL	FL	65.2	75.8	4.5	0.8	(14)	CL		KL	47.2	57.8	LAS25	AL	EL	FL	81.4	92	4.5	0.8	(14)	CL		KL	59.4	70	LAS30	AL	EL	FL	96.4	108.4	5.0	1.0	(14)	CL		KL	67.4	79.4	LAS35	AL	EL	FL	108	121	5.5	1.0	(14)	CL		KL	77	90	LAW17	EL			51.4	61.6	4.5	0.6	(5)	LAW21	EL			58.8	71.4	5.5	0.8	(13)	LAW27	EL			74	86.6	5.5	0.8	(13)	LAW35	EL			108	123	6.5	1.0	(13)	LAW50	EL			140.6	155.6	6.5	1.0	(14)	LAU09	AR	TR		30	36.4	2.7	0.5	–	LAU12	AR	TR		35.2	42.2	3.0	0.5	–	LAU15			AL	43.6	51.8	3.5	0.6	–	LAE09	AR	TR		39.8	46.8	3.0	0.5	–	LAE12	AR			45	53	3.5	0.5	–	LAE15	AR			56.6
LAH20	AN	EL	FL	69.8	80.4	4.5	0.8	(14)																																																																																																																																																																																																																																																																							
	BN	GL	HL	91.8	102.4				LAH25	AN	EL	FL	79	90.6	5.0	0.8	(14)	BN	GL	HL	107	118.6	LAH30	AN	EL	FL	85.6	97.6	5.0	1.0	(14)	BN	GL	HL	98.6	110.6	LAH35	AN	EL	FL	109	122	5.5	1.0	(14)	BN	GL	HL	143	156	LAH45	AN	EL	FL	139	154	6.5	1.0	(15)	BN	GL	HL	171	186	LAH55	AN	EL	FL	163	178	6.5	1.0	(15)	BN	GL	HL	201	216	LAH65**	AN	EL	FL	193	211	8.0	1.0	(16)	BN	GL	HL	253	271	LAS15	AL	EL	FL	56.8	66.4	4.0	0.8	(5)	CL		KL	40.4	50	LAS20	AL	EL	FL	65.2	75.8	4.5	0.8	(14)	CL		KL	47.2	57.8	LAS25	AL	EL	FL	81.4	92	4.5	0.8	(14)	CL		KL	59.4	70	LAS30	AL	EL	FL	96.4	108.4	5.0	1.0	(14)	CL		KL	67.4	79.4	LAS35	AL	EL	FL	108	121	5.5	1.0	(14)	CL		KL	77	90	LAW17	EL			51.4	61.6	4.5	0.6	(5)	LAW21	EL			58.8	71.4	5.5	0.8	(13)	LAW27	EL			74	86.6	5.5	0.8	(13)	LAW35	EL			108	123	6.5	1.0	(13)	LAW50	EL			140.6	155.6	6.5	1.0	(14)	LAU09	AR	TR		30	36.4	2.7	0.5	–	LAU12	AR	TR		35.2	42.2	3.0	0.5	–	LAU15			AL	43.6	51.8	3.5	0.6	–	LAE09	AR	TR		39.8	46.8	3.0	0.5	–	LAE12	AR			45	53	3.5	0.5	–	LAE15	AR			56.6	66.2	4.0	0.8	–										
LAH25	AN	EL	FL	79	90.6	5.0	0.8	(14)																																																																																																																																																																																																																																																																							
	BN	GL	HL	107	118.6				LAH30	AN	EL	FL	85.6	97.6	5.0	1.0	(14)	BN	GL	HL	98.6	110.6	LAH35	AN	EL	FL	109	122	5.5	1.0	(14)	BN	GL	HL	143	156	LAH45	AN	EL	FL	139	154	6.5	1.0	(15)	BN	GL	HL	171	186	LAH55	AN	EL	FL	163	178	6.5	1.0	(15)	BN	GL	HL	201	216	LAH65**	AN	EL	FL	193	211	8.0	1.0	(16)	BN	GL	HL	253	271	LAS15	AL	EL	FL	56.8	66.4	4.0	0.8	(5)	CL		KL	40.4	50	LAS20	AL	EL	FL	65.2	75.8	4.5	0.8	(14)	CL		KL	47.2	57.8	LAS25	AL	EL	FL	81.4	92	4.5	0.8	(14)	CL		KL	59.4	70	LAS30	AL	EL	FL	96.4	108.4	5.0	1.0	(14)	CL		KL	67.4	79.4	LAS35	AL	EL	FL	108	121	5.5	1.0	(14)	CL		KL	77	90	LAW17	EL			51.4	61.6	4.5	0.6	(5)	LAW21	EL			58.8	71.4	5.5	0.8	(13)	LAW27	EL			74	86.6	5.5	0.8	(13)	LAW35	EL			108	123	6.5	1.0	(13)	LAW50	EL			140.6	155.6	6.5	1.0	(14)	LAU09	AR	TR		30	36.4	2.7	0.5	–	LAU12	AR	TR		35.2	42.2	3.0	0.5	–	LAU15			AL	43.6	51.8	3.5	0.6	–	LAE09	AR	TR		39.8	46.8	3.0	0.5	–	LAE12	AR			45	53	3.5	0.5	–	LAE15	AR			56.6	66.2	4.0	0.8	–																								
LAH30	AN	EL	FL	85.6	97.6	5.0	1.0	(14)																																																																																																																																																																																																																																																																							
	BN	GL	HL	98.6	110.6				LAH35	AN	EL	FL	109	122	5.5	1.0	(14)	BN	GL	HL	143	156	LAH45	AN	EL	FL	139	154	6.5	1.0	(15)	BN	GL	HL	171	186	LAH55	AN	EL	FL	163	178	6.5	1.0	(15)	BN	GL	HL	201	216	LAH65**	AN	EL	FL	193	211	8.0	1.0	(16)	BN	GL	HL	253	271	LAS15	AL	EL	FL	56.8	66.4	4.0	0.8	(5)	CL		KL	40.4	50	LAS20	AL	EL	FL	65.2	75.8	4.5	0.8	(14)	CL		KL	47.2	57.8	LAS25	AL	EL	FL	81.4	92	4.5	0.8	(14)	CL		KL	59.4	70	LAS30	AL	EL	FL	96.4	108.4	5.0	1.0	(14)	CL		KL	67.4	79.4	LAS35	AL	EL	FL	108	121	5.5	1.0	(14)	CL		KL	77	90	LAW17	EL			51.4	61.6	4.5	0.6	(5)	LAW21	EL			58.8	71.4	5.5	0.8	(13)	LAW27	EL			74	86.6	5.5	0.8	(13)	LAW35	EL			108	123	6.5	1.0	(13)	LAW50	EL			140.6	155.6	6.5	1.0	(14)	LAU09	AR	TR		30	36.4	2.7	0.5	–	LAU12	AR	TR		35.2	42.2	3.0	0.5	–	LAU15			AL	43.6	51.8	3.5	0.6	–	LAE09	AR	TR		39.8	46.8	3.0	0.5	–	LAE12	AR			45	53	3.5	0.5	–	LAE15	AR			56.6	66.2	4.0	0.8	–																																						
LAH35	AN	EL	FL	109	122	5.5	1.0	(14)																																																																																																																																																																																																																																																																							
	BN	GL	HL	143	156				LAH45	AN	EL	FL	139	154	6.5	1.0	(15)	BN	GL	HL	171	186	LAH55	AN	EL	FL	163	178	6.5	1.0	(15)	BN	GL	HL	201	216	LAH65**	AN	EL	FL	193	211	8.0	1.0	(16)	BN	GL	HL	253	271	LAS15	AL	EL	FL	56.8	66.4	4.0	0.8	(5)	CL		KL	40.4	50	LAS20	AL	EL	FL	65.2	75.8	4.5	0.8	(14)	CL		KL	47.2	57.8	LAS25	AL	EL	FL	81.4	92	4.5	0.8	(14)	CL		KL	59.4	70	LAS30	AL	EL	FL	96.4	108.4	5.0	1.0	(14)	CL		KL	67.4	79.4	LAS35	AL	EL	FL	108	121	5.5	1.0	(14)	CL		KL	77	90	LAW17	EL			51.4	61.6	4.5	0.6	(5)	LAW21	EL			58.8	71.4	5.5	0.8	(13)	LAW27	EL			74	86.6	5.5	0.8	(13)	LAW35	EL			108	123	6.5	1.0	(13)	LAW50	EL			140.6	155.6	6.5	1.0	(14)	LAU09	AR	TR		30	36.4	2.7	0.5	–	LAU12	AR	TR		35.2	42.2	3.0	0.5	–	LAU15			AL	43.6	51.8	3.5	0.6	–	LAE09	AR	TR		39.8	46.8	3.0	0.5	–	LAE12	AR			45	53	3.5	0.5	–	LAE15	AR			56.6	66.2	4.0	0.8	–																																																				
LAH45	AN	EL	FL	139	154	6.5	1.0	(15)																																																																																																																																																																																																																																																																							
	BN	GL	HL	171	186				LAH55	AN	EL	FL	163	178	6.5	1.0	(15)	BN	GL	HL	201	216	LAH65**	AN	EL	FL	193	211	8.0	1.0	(16)	BN	GL	HL	253	271	LAS15	AL	EL	FL	56.8	66.4	4.0	0.8	(5)	CL		KL	40.4	50	LAS20	AL	EL	FL	65.2	75.8	4.5	0.8	(14)	CL		KL	47.2	57.8	LAS25	AL	EL	FL	81.4	92	4.5	0.8	(14)	CL		KL	59.4	70	LAS30	AL	EL	FL	96.4	108.4	5.0	1.0	(14)	CL		KL	67.4	79.4	LAS35	AL	EL	FL	108	121	5.5	1.0	(14)	CL		KL	77	90	LAW17	EL			51.4	61.6	4.5	0.6	(5)	LAW21	EL			58.8	71.4	5.5	0.8	(13)	LAW27	EL			74	86.6	5.5	0.8	(13)	LAW35	EL			108	123	6.5	1.0	(13)	LAW50	EL			140.6	155.6	6.5	1.0	(14)	LAU09	AR	TR		30	36.4	2.7	0.5	–	LAU12	AR	TR		35.2	42.2	3.0	0.5	–	LAU15			AL	43.6	51.8	3.5	0.6	–	LAE09	AR	TR		39.8	46.8	3.0	0.5	–	LAE12	AR			45	53	3.5	0.5	–	LAE15	AR			56.6	66.2	4.0	0.8	–																																																																		
LAH55	AN	EL	FL	163	178	6.5	1.0	(15)																																																																																																																																																																																																																																																																							
	BN	GL	HL	201	216				LAH65**	AN	EL	FL	193	211	8.0	1.0	(16)	BN	GL	HL	253	271	LAS15	AL	EL	FL	56.8	66.4	4.0	0.8	(5)	CL		KL	40.4	50	LAS20	AL	EL	FL	65.2	75.8	4.5	0.8	(14)	CL		KL	47.2	57.8	LAS25	AL	EL	FL	81.4	92	4.5	0.8	(14)	CL		KL	59.4	70	LAS30	AL	EL	FL	96.4	108.4	5.0	1.0	(14)	CL		KL	67.4	79.4	LAS35	AL	EL	FL	108	121	5.5	1.0	(14)	CL		KL	77	90	LAW17	EL			51.4	61.6	4.5	0.6	(5)	LAW21	EL			58.8	71.4	5.5	0.8	(13)	LAW27	EL			74	86.6	5.5	0.8	(13)	LAW35	EL			108	123	6.5	1.0	(13)	LAW50	EL			140.6	155.6	6.5	1.0	(14)	LAU09	AR	TR		30	36.4	2.7	0.5	–	LAU12	AR	TR		35.2	42.2	3.0	0.5	–	LAU15			AL	43.6	51.8	3.5	0.6	–	LAE09	AR	TR		39.8	46.8	3.0	0.5	–	LAE12	AR			45	53	3.5	0.5	–	LAE15	AR			56.6	66.2	4.0	0.8	–																																																																																
LAH65**	AN	EL	FL	193	211	8.0	1.0	(16)																																																																																																																																																																																																																																																																							
	BN	GL	HL	253	271				LAS15	AL	EL	FL	56.8	66.4	4.0	0.8	(5)	CL		KL	40.4	50	LAS20	AL	EL	FL	65.2	75.8	4.5	0.8	(14)	CL		KL	47.2	57.8	LAS25	AL	EL	FL	81.4	92	4.5	0.8	(14)	CL		KL	59.4	70	LAS30	AL	EL	FL	96.4	108.4	5.0	1.0	(14)	CL		KL	67.4	79.4	LAS35	AL	EL	FL	108	121	5.5	1.0	(14)	CL		KL	77	90	LAW17	EL			51.4	61.6	4.5	0.6	(5)	LAW21	EL			58.8	71.4	5.5	0.8	(13)	LAW27	EL			74	86.6	5.5	0.8	(13)	LAW35	EL			108	123	6.5	1.0	(13)	LAW50	EL			140.6	155.6	6.5	1.0	(14)	LAU09	AR	TR		30	36.4	2.7	0.5	–	LAU12	AR	TR		35.2	42.2	3.0	0.5	–	LAU15			AL	43.6	51.8	3.5	0.6	–	LAE09	AR	TR		39.8	46.8	3.0	0.5	–	LAE12	AR			45	53	3.5	0.5	–	LAE15	AR			56.6	66.2	4.0	0.8	–																																																																																														
LAS15	AL	EL	FL	56.8	66.4	4.0	0.8	(5)																																																																																																																																																																																																																																																																							
	CL		KL	40.4	50				LAS20	AL	EL	FL	65.2	75.8	4.5	0.8	(14)	CL		KL	47.2	57.8	LAS25	AL	EL	FL	81.4	92	4.5	0.8	(14)	CL		KL	59.4	70	LAS30	AL	EL	FL	96.4	108.4	5.0	1.0	(14)	CL		KL	67.4	79.4	LAS35	AL	EL	FL	108	121	5.5	1.0	(14)	CL		KL	77	90	LAW17	EL			51.4	61.6	4.5	0.6	(5)	LAW21	EL			58.8	71.4	5.5	0.8	(13)	LAW27	EL			74	86.6	5.5	0.8	(13)	LAW35	EL			108	123	6.5	1.0	(13)	LAW50	EL			140.6	155.6	6.5	1.0	(14)	LAU09	AR	TR		30	36.4	2.7	0.5	–	LAU12	AR	TR		35.2	42.2	3.0	0.5	–	LAU15			AL	43.6	51.8	3.5	0.6	–	LAE09	AR	TR		39.8	46.8	3.0	0.5	–	LAE12	AR			45	53	3.5	0.5	–	LAE15	AR			56.6	66.2	4.0	0.8	–																																																																																																												
LAS20	AL	EL	FL	65.2	75.8	4.5	0.8	(14)																																																																																																																																																																																																																																																																							
	CL		KL	47.2	57.8				LAS25	AL	EL	FL	81.4	92	4.5	0.8	(14)	CL		KL	59.4	70	LAS30	AL	EL	FL	96.4	108.4	5.0	1.0	(14)	CL		KL	67.4	79.4	LAS35	AL	EL	FL	108	121	5.5	1.0	(14)	CL		KL	77	90	LAW17	EL			51.4	61.6	4.5	0.6	(5)	LAW21	EL			58.8	71.4	5.5	0.8	(13)	LAW27	EL			74	86.6	5.5	0.8	(13)	LAW35	EL			108	123	6.5	1.0	(13)	LAW50	EL			140.6	155.6	6.5	1.0	(14)	LAU09	AR	TR		30	36.4	2.7	0.5	–	LAU12	AR	TR		35.2	42.2	3.0	0.5	–	LAU15			AL	43.6	51.8	3.5	0.6	–	LAE09	AR	TR		39.8	46.8	3.0	0.5	–	LAE12	AR			45	53	3.5	0.5	–	LAE15	AR			56.6	66.2	4.0	0.8	–																																																																																																																										
LAS25	AL	EL	FL	81.4	92	4.5	0.8	(14)																																																																																																																																																																																																																																																																							
	CL		KL	59.4	70				LAS30	AL	EL	FL	96.4	108.4	5.0	1.0	(14)	CL		KL	67.4	79.4	LAS35	AL	EL	FL	108	121	5.5	1.0	(14)	CL		KL	77	90	LAW17	EL			51.4	61.6	4.5	0.6	(5)	LAW21	EL			58.8	71.4	5.5	0.8	(13)	LAW27	EL			74	86.6	5.5	0.8	(13)	LAW35	EL			108	123	6.5	1.0	(13)	LAW50	EL			140.6	155.6	6.5	1.0	(14)	LAU09	AR	TR		30	36.4	2.7	0.5	–	LAU12	AR	TR		35.2	42.2	3.0	0.5	–	LAU15			AL	43.6	51.8	3.5	0.6	–	LAE09	AR	TR		39.8	46.8	3.0	0.5	–	LAE12	AR			45	53	3.5	0.5	–	LAE15	AR			56.6	66.2	4.0	0.8	–																																																																																																																																								
LAS30	AL	EL	FL	96.4	108.4	5.0	1.0	(14)																																																																																																																																																																																																																																																																							
	CL		KL	67.4	79.4				LAS35	AL	EL	FL	108	121	5.5	1.0	(14)	CL		KL	77	90	LAW17	EL			51.4	61.6	4.5	0.6	(5)	LAW21	EL			58.8	71.4	5.5	0.8	(13)	LAW27	EL			74	86.6	5.5	0.8	(13)	LAW35	EL			108	123	6.5	1.0	(13)	LAW50	EL			140.6	155.6	6.5	1.0	(14)	LAU09	AR	TR		30	36.4	2.7	0.5	–	LAU12	AR	TR		35.2	42.2	3.0	0.5	–	LAU15			AL	43.6	51.8	3.5	0.6	–	LAE09	AR	TR		39.8	46.8	3.0	0.5	–	LAE12	AR			45	53	3.5	0.5	–	LAE15	AR			56.6	66.2	4.0	0.8	–																																																																																																																																																						
LAS35	AL	EL	FL	108	121	5.5	1.0	(14)																																																																																																																																																																																																																																																																							
	CL		KL	77	90				LAW17	EL			51.4	61.6	4.5	0.6	(5)	LAW21	EL			58.8	71.4	5.5	0.8	(13)	LAW27	EL			74	86.6	5.5	0.8	(13)	LAW35	EL			108	123	6.5	1.0	(13)	LAW50	EL			140.6	155.6	6.5	1.0	(14)	LAU09	AR	TR		30	36.4	2.7	0.5	–	LAU12	AR	TR		35.2	42.2	3.0	0.5	–	LAU15			AL	43.6	51.8	3.5	0.6	–	LAE09	AR	TR		39.8	46.8	3.0	0.5	–	LAE12	AR			45	53	3.5	0.5	–	LAE15	AR			56.6	66.2	4.0	0.8	–																																																																																																																																																																				
LAW17	EL			51.4	61.6	4.5	0.6	(5)																																																																																																																																																																																																																																																																							
LAW21	EL			58.8	71.4	5.5	0.8	(13)																																																																																																																																																																																																																																																																							
LAW27	EL			74	86.6	5.5	0.8	(13)																																																																																																																																																																																																																																																																							
LAW35	EL			108	123	6.5	1.0	(13)																																																																																																																																																																																																																																																																							
LAW50	EL			140.6	155.6	6.5	1.0	(14)																																																																																																																																																																																																																																																																							
LAU09	AR	TR		30	36.4	2.7	0.5	–																																																																																																																																																																																																																																																																							
LAU12	AR	TR		35.2	42.2	3.0	0.5	–																																																																																																																																																																																																																																																																							
LAU15			AL	43.6	51.8	3.5	0.6	–																																																																																																																																																																																																																																																																							
LAE09	AR	TR		39.8	46.8	3.0	0.5	–																																																																																																																																																																																																																																																																							
LAE12	AR			45	53	3.5	0.5	–																																																																																																																																																																																																																																																																							
LAE15	AR			56.6	66.2	4.0	0.8	–																																																																																																																																																																																																																																																																							

LH, LS Series

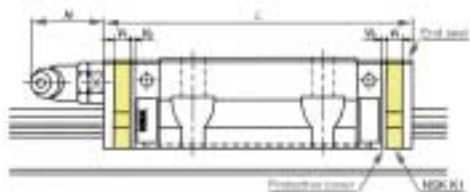

LU, LE Series

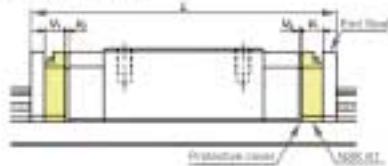

LW Series

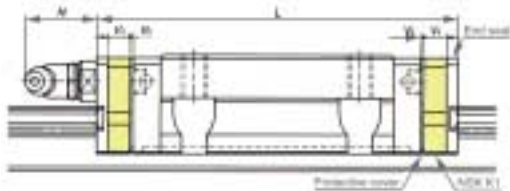

Note: For more bearing seal options see page 4.

* For Protector and Double Seal Information for LH Series please see page 14.

For Protector and Double Seal Information for LS Series please see page 22.

**Contact NSK for information on assembly instructions.



K1 Lubrication Unit Handling and Assembly Instructions

Handling Instructions

To maintain the NSK K1 Seal's high efficiency over a long period of time, please follow these instructions.

1 Permissible temperature range
Max. operating temperature: 50°C (122°F)
Max. peak temperature: 80°C (176°F)
If not installed immediately, they should be kept refrigerated.
Avoid storage in direct sunlight.

2 Never leave the linear guide in close proximity to grease-removing organic solvents such as hexane, thinners, etc.
Never immerse the linear guide in kerosene or rust preventative oils which contain kerosene.

Note

Other oils such as: water-based cutting oil, oil-based cutting oil, grease (mineral oil-AV2, ester-PS2) present no problems to the K1 lubricating units performance.

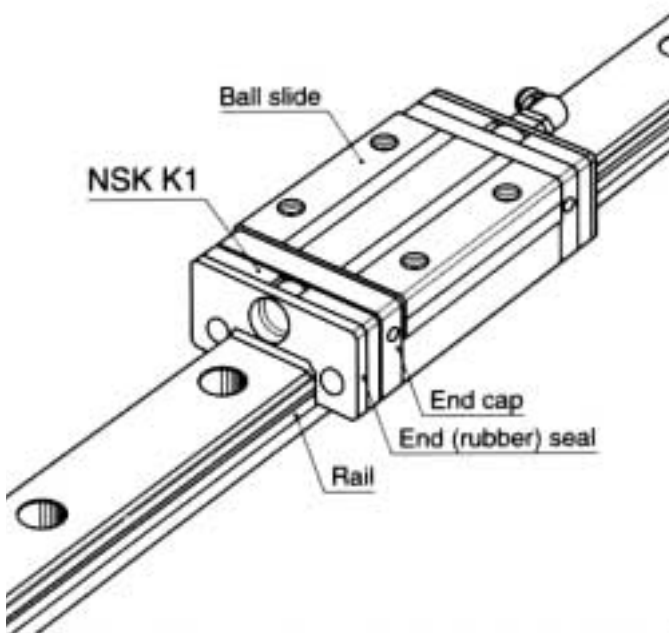

Assembly Instructions for the K1 Lubricating Unit for Linear Guides

1. Slide linear bearing on to the linear rail, using the plastic provisional rail supplied.
2. Remove the grease fitting from the end of the bearing.
3. Remove the Phillips screws (2 pieces).
4. Remove the end seal from end of bearing.
5. Install threaded plug from K1 kit (or see option 9 and 10 depending on application).
6. Install the cover plate from the K1 kit, to the end of bearing, against the end cap.
7. Install K1 lubricating unit without fixing rings, so it can be expanded over the rail.
8. Put the three (3) fixing rings in position on the K1 lubricating unit.
9. Replace the end seal, in front of the K1 lubricating unit.
10. Install connector screw for grease fitting.
11. Replace the grease fitting in connector screw.
12. Install the **extension** Phillips screws (2 pieces, supplied with the K1 seal kit).

Note* The K1 lubricating unit has a shelf life. They should be installed immediately upon receipt. It is important to avoid direct sun light and extreme heat conditions.

**UNIT CONVERSIONS
TO CONVERT**

FROM	TO	MULTIPLY BY
daN	N	10.000
kgf	N	9.81
kgf	lbf	2.205
kgf.cm	lbf.in	0.868
kgf.cm	ozf.in	13.890
kgf.m	lbf.ft	7.234
kgf.m	lbf.in	86.811
N.m	lbf.ft	0.738
mm	inch	0.03937
inch	mm	25.4

MONTREAL

2150-32e Avenue
Lachine, QC
H8T 3H7
Tel: (514) 633-1220
Fax: (514) 633-8164
Wats: 1-800-361-5861

TORONTO

5585 McAdam Road
Mississauga, ON
L4Z 1N4
Tel: (905) 890-0561
Fax: (905) 890-1938
Wats: 1-800-387-9362

EDMONTON

9267-41 Avenue
Edmonton, AB
T6E 6R5
Wats: 1-800-663-5445
Wats Fax: 1-800-800-2788

VANCOUVER

3353 Wayburne Drive
Burnaby, BC
V5G 4L4
Tel: (604) 294-1151
Fax: (604) 294-1407
Wats: 1-800-663-5445
Wats Fax: 1-800-800-2788

HEAD OFFICE

5585 McAdam Road
Mississauga, ON
L4Z 1N4
Tel: (905) 890-0740
Fax: (905) 890-0434
www.ca.nsk.com
info@ca.nsk.com

